

RECOMMEND PC BOARD LAYOUT

Material:
 Plastic Body : LCP+35%GF, Color Black.
 Slider : LCP+35%GF, Color Black.

Contact :Phosphor Bronze Alloy (C5210R-EH)
 Contacts Plating:Contact area: Gold 10 micro inches (Min.)
 Solder area: Gold flash
 All under-plated Ductile Nickel 50 micro inches (Min.)

Shell :SUS304R-3/4H
 Plating:
 Contact area: Gold flash
 Solder area: Gold flash
 All under-plated Ductile Nickel 12 micro inches (Min.)

Spring : Piano Wire
 Drag Link : SUS304

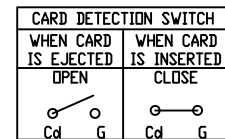

PART NAME	Q'TY	MATERIAL
BODY	1	LCP+35%GF
SLIDER	1	LCP+35%GF
CONTACT	1	C5210R-EH
SHELL	1	SUS304R-3/4H
DRAG LINK	1	SUS304
SPRING	1	PIANO WIRE

PIN NUMBER	PIN ASSIGNMENT	PIN NUMBER	PIN ASSIGNMENT
1	DAT2	6	VSS
2	CD/DAT3	7	DAT0
3	CMD	8	DAT1
4	VDD	Cd	CARD DETECTION
5	CLK	G	GROUND

RoHS Compliant

TOLERANCES ARE

MORETHANALL
 PCB CONNECTORS
 Cable ASSEMBLIES

DRAWING BY CY
 CHECKED BY GENIUS
 UNIT / mm SCALE 1 : 1
 DATE

X, ±
 .X ±
 .XX ±
 .XXX ±
 ANG ±

煜倫股份有限公司

www.morethanall.com

SIZE A4

PJECTION

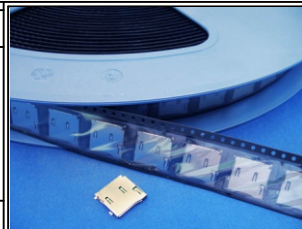

ORDER INFORMATION

TFC-WPBPO8R-08-LF
 SERIES | | | | LEADFREE
 | | | | 08WAY
 | | | | REEL
 90°SMT | | | | POST 8.0mm
 | | | | BOTTOM CONTACT
 | | | | PUSH PUSH

DESCRIPTION:Micro SD Socket Push-Push Type

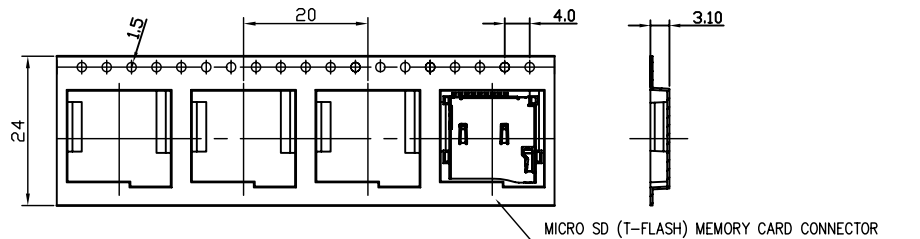

NOTES:

1. PACKING STYLE 1,000 PCS/REEL
2 REEL/INNER CARTON
10,000 PCS/OUTER CARTON
2. MATERIAL CARRIER TAPE:PS BLACK
COVER TAPE:PET FILM
REEL:PLASTIC
3. PEEL STRENGTH OF COVER TAPE:20-80g(PEEL SPEED 300mm/MINUTE).

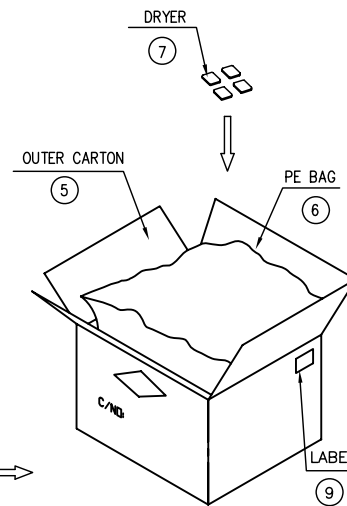
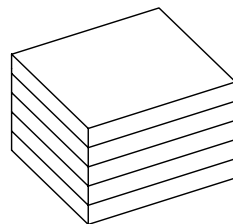
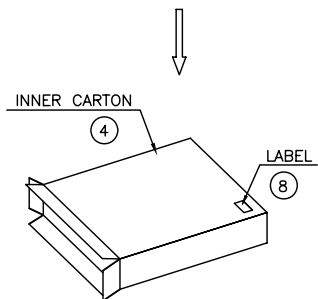
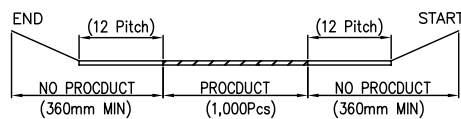
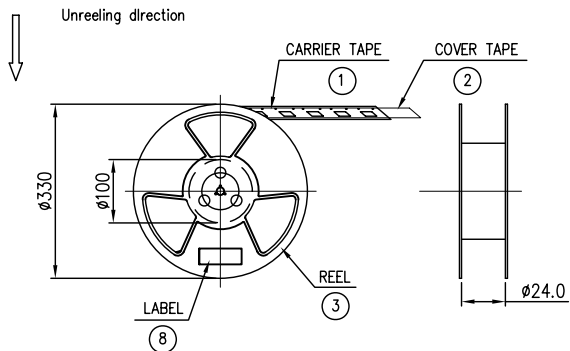

10	PROTECTIVE TAPE	1	PCS	
9	LABEL	1	PCS	
8	LABEL	15	PCS	
7	DRYER	4	BAG	
6	PE BAG	1	PCS	L850*W750mm
5	OUTER CARTON	1	PCS	
4	INNER CARTON	5	PCS	
3	REEL	10	SET	φ330*100mm,W=24mm
2	COVER TAPE	1,000	10	PCS W=21.5mm,20.8M
1	CARRIER TAPE			W=24mm,T=0.35mm,20.8M/REEL
NO.	PACKING NAME	PCS/T	T/BOX	UNIT
		PACKING	QTY	NOTE

RoHS Compliant

TOLERANCES ARE

MORETHANALL
PCB CONNECTORS
Cable ASSEMBLIES

DRAWING BY CY

X. ±

CHECKED BY GENIUS

.X ±

UNIT / mm

SCALE 1 : 1

.XXX ±

DATE

ANG ±

SIZE A4

PPOJECTION

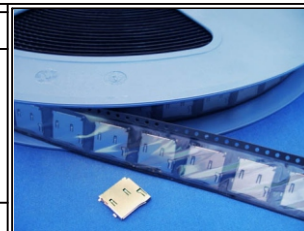

ORDER INFORMATION

TFC-WPBP08R-08-LF
SERIES | | | | | LEADFREE
| | | | | 08WAY
| | | | | REEL
90°SMT | | | | | POST 8.0mm
| | | | | BOTTOM CONTACT
| | | | | PUSH PUSH

DESCRIPTION:Micro SD Socket Push-Push Type

煜倫股份有限公司

www.morethanall.com