

TOLERANCE: ±0.05
RECOMMENDED P.C.B. Layout
TOP VIEW

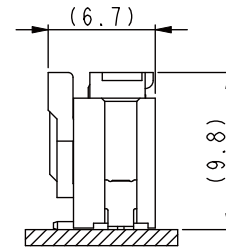
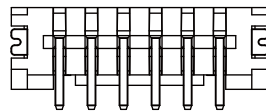
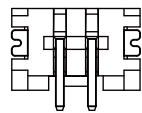
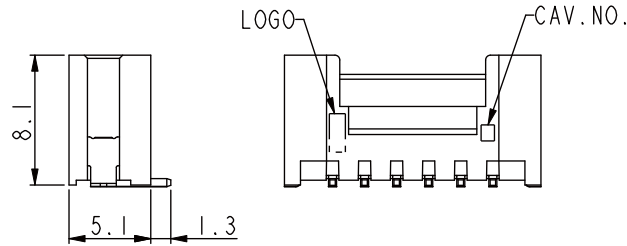
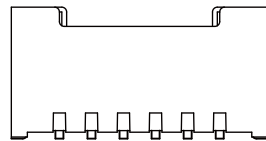
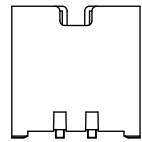

PIN	DIM. (mm)	
	A	B
02	2.00	8.00
03	4.00	10.00
04	6.00	12.00
05	8.00	14.00
06	10.00	16.00
07	12.00	18.00
08	14.00	20.00
09	16.00	22.00
10	18.00	24.00
11	20.00	26.00
12	22.00	28.00
13	24.00	30.00
14	26.00	32.00
15	28.00	34.00
16	30.00	36.00

NOTES

- MATERIAL
INSULATION: NYLON 9T, UL94V-0(HALOGEN FREE); COLOR: SEE NOTE 4
COVER: NYLON 9T, UL94V-0(HALOGEN FREE); COLOR: BLACK
CONTACT: COPPER ALLOY, 0.50mm SQUARE PIN
SOLDER TAB: COPPER ALLOY, ±0.20mm / MATTE-TIN PLATED OVER NICKEL
- CONTACT FINISH: (1) MATTE TIN PLATED OVER NICKEL
(2) *u"min. GOLD PLATED ON CONTACT AREA, GOLD FLASH ON SOLDER TAIL, OVER NICKEL

RoHS Compliant

TOLERANCES ARE

MORETHANALL
PCB CONNECTORS
Cable ASSEMBLIES

煜倫股份有限公司

www.morethanall.com

DRAWING BY CY

CHECKED BY GENIUS

UNIT / mm SCALE 1 : 1

DATE

SIZE A4

X, ±
.X ± 0.25
.XX ± 0.15
.XXX ±
ANG ± 3°

P PROJECTION

照片框

ORDER INFORMATION

YH20-VCR-xx-LF

SERIES
LEADFREE
02~16WAY
REEL
CAP
180°SMT

DESCRIPTION: WIRE TO BOARD, PITCH 2.00 mm, VERTICAL, SMT TYPE, ASSEMBLY

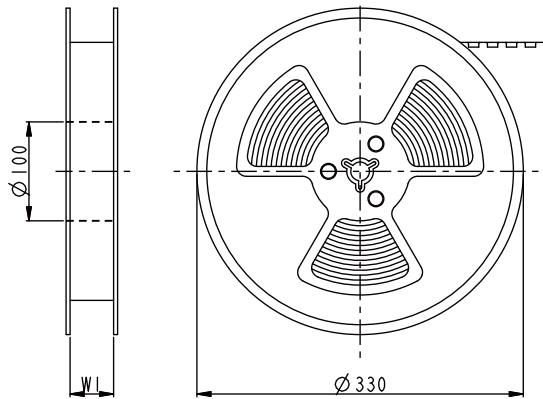
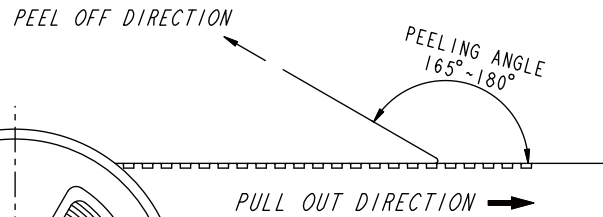
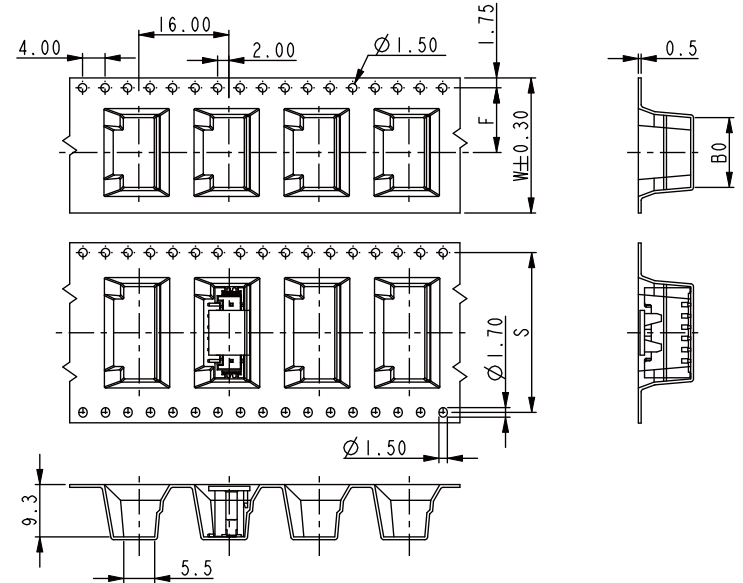
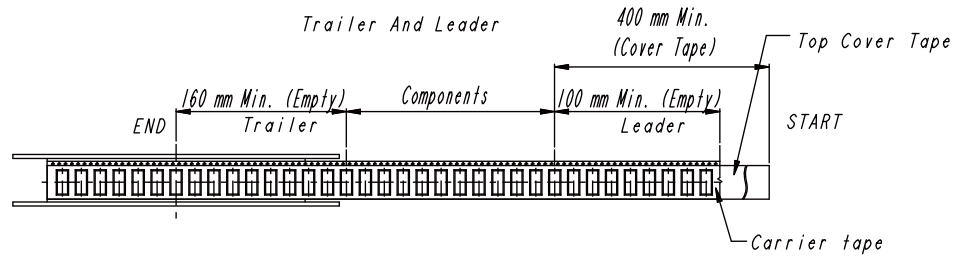

1. 10 SPROCKET HOLE PITCH CUMULATIVE TOLERANCE ± 0.20
2. CARRIER CAMBER IS WITHIN 1 mm IN 250 mm
3. THE TOTAL TEARING CONTROL RANGE OF TOP COVER TAPE IS 10~130g, REFERENCE SPEC: EIA-481-D
4. PEELING SPEED: 300mm/MINUTES, REFERENCE SPEC: EIA-481-D
5. MATERIAL: TRANSPARENT CONDUCTIVE POLYSTYRENE ALLOY.(UP-5000)
6. ALL DIMENSIONS MEET EIA-481-D REQUIREMENTS
7. THICKNESS : 0.50 ± 0.05 mm
8. COMPONENT LOAD PER 13" REEL : 400 PCS

PIN	DIM. (mm)					PIN	DIM. (mm)				
	B0	F	S	W	W1		B0	F	S	W	W1
02	8.4	11.5	--	24.0	24.5	10	24.4	20.2	40.4	44.0	44.5
03	10.4					11	26.4				
04	12.4					12	28.4				
05	14.4	14.2	28.4	32.0	32.5	13	30.4	26.2	52.4	56.0	56.5
06	16.4					14	32.4				
07	18.4	20.2	40.4	44.0	44.5	15	34.4	26.2	52.4	56.0	56.5
08	20.4					16	36.4				
09	22.4										

RoHS Compliant

TOLERANCES ARE

MORETHANALL
PCB CONNECTORS
Cable ASSEMBLIES

DRAWING BY CY

CHECKED BY GENIUS

UNIT / mm

SCALE 1:1

DATE

SIZE A4

PJECTION

X, ±
.X ± 0.25
.XX ± 0.15
.XXX ±
ANG ± 3°

照片框

ORDER INFORMATION

YH20-VCR-xx-LF

SERIES LEADFREE
02~16WAY
REEL
CAP
180°SMT

DESCRIPTION: WIRE TO BOARD, PITCH 2.00 mm, VERTICAL, SMT TYPE, ASSEMBLY

煜倫股份有限公司

www.morethanall.com

PARTITION BOARD 2 PCS

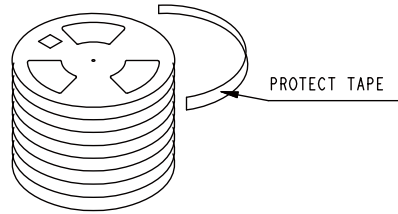
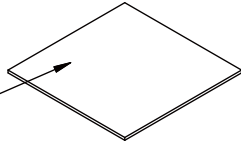

PROTECT TAPE

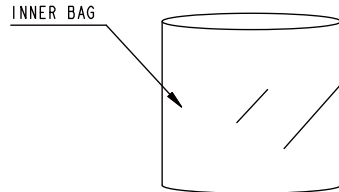

INNER BAG



TRIANGLE BOARD 4 PCS

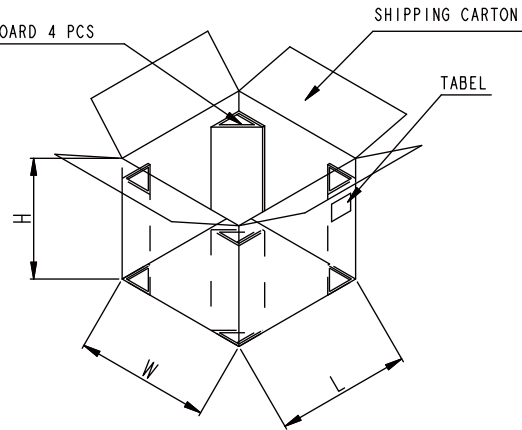

SHIPPING CARTON

TABEL

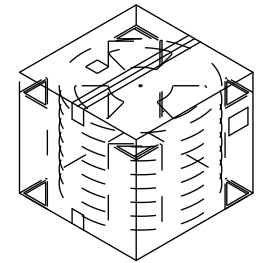

PACKING MATERIAL		PACKING CAPACITY			
PART NAME	DIM. (mm)	PIN	PCS/RE	RE/BC	PCS/BC
REEL	∅330*(W+0.5)	02~04	400	9	3,600
CARTON	350*350*340	05~06		7	2,800
		07~13		6	2,400
		14~16		5	2,000

RoHS Compliant

TOLERANCES ARE

MORETHANALL
PCB CONNECTORS
Cable ASSEMBLIES

DRAWING BY CY

CHECKED BY GENIUS

UNIT / mm

SCALE 1 : 1

DATE

SIZE A4

X, ±
.X ± 0.25
.XX ± 0.15
.XXX ±
ANG ± 3°

P PROJECTION

照片框

ORDER INFORMATION

YH20-VCR-xx-LF
SERIES LEADFREE
02~16WAY
REEL
CAP
180°SMT

煜倫股份有限公司

www.morethanall.com

DESCRIPTION: WIRE TO BOARD, PITCH 2.00 mm, VERTICAL, SMT TYPE, ASSEMBLY