

RECOMMENDED P.C.B. LAYOUT GENERAL
TOLERANCE±0.05 P.C.B. T=0.7mm

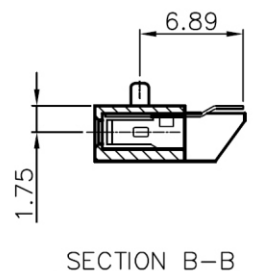
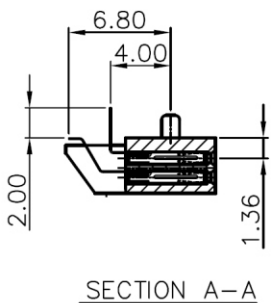
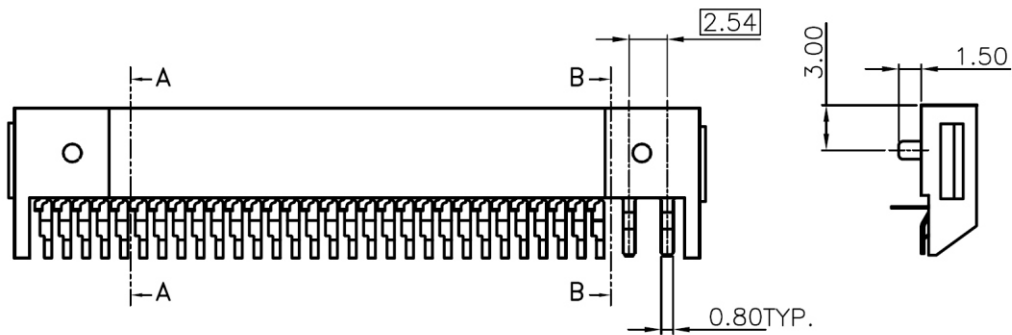

- NOTES:
- MATERIAL
HOUSING: THERMOPLASTIC, COLOR IN BLACK, UL94V-0 RA
CONTACT: HIGH PERFORMANCE COPPER ALLOY.
 - NON GREEN PRODUCT FINISH:
50u" MIN. NICKEL UNDER-PLATING ALL OVER.
GOLD PLATING SEE ORDER INFORMATION.
100u" MIN. 90-10 TIN-LEAD PLATING ON SOLDER TAIL.
 - GREEN PRODUCT FINISH:
50u" MIN. NICKEL UNDER-PLATING ALL OVER
GOLD PLATING SEE ORDER INFORMATION.
100u" MIN. MALT PURE TIN ON TAIL AREA
 - RECOMMEND REFLOW TEMPERATURE
NYLON 6T 235°C 15 SECOND(MAX)

YAW-WRP-60+2-LF
LEADFREE

RoHS Compliant



PART NO. **YAW-WRP-60+2**

DWG NO. **YAW-WRP-60+2**

FILE NO.

UNIT / mm

SCALE 1:1

CHECKED BY CY

DRAWING BY

PROJECTION

TOLERANCES ARE

.X±0.2
.XX±
.XXX±
AWG

| | | | |
|---------------|-----------|----|------|
| DESCRIP TION: | | | |
| AREA | REVISIONS | HK | DATE |

焯倫股份有限公司