

Dim.C	NOTE
4.00	03~25PIN
10.15	26~50PIN

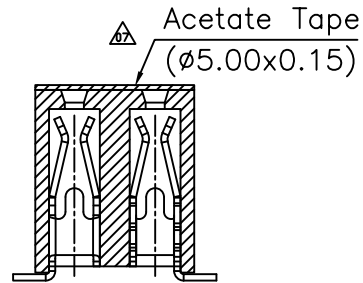

Specifications

Current Rating:1Amp
 Insulation Resistance:1000MΩMin.
 Dielectric Withstanding Voltage:300VAC
 Contact Resistance:20mΩMax.
 Operating Temperature:-40°C to +105°C
 Materials

Contact Material:Phosphor Bronze
 Insulator Material:High Temperature Thermoplastic, UL 94V-0 LCP or the equivalent material

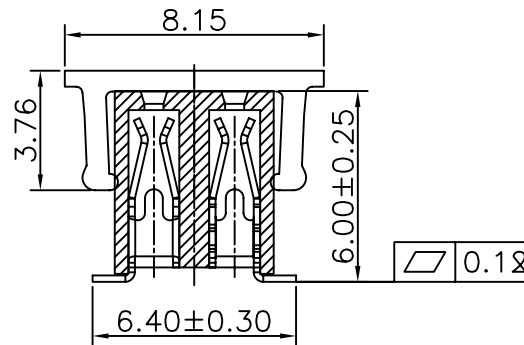
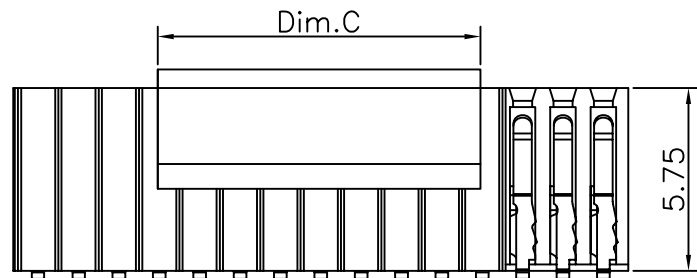

Recommended P.C.Board Layout
 (Tolerance:±0.05)

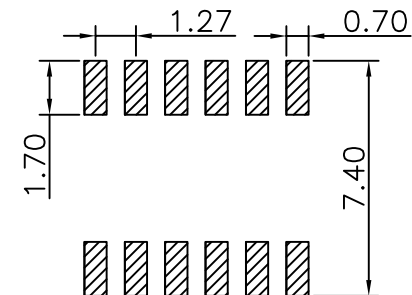

RoHS Compliant

TOLERANCES ARE

MORETHANALL
 PCB CONNECTORS
 Cable ASSEMBLIES

煜倫股份有限公司

www.morethanall.com

DRAWING BY CY

CHECKED BY GENIUS

UNIT / mm

SCALE 1 : 1

DATE

SIZE A4

X. ± 0.30

.X ± 0.25

.XX ± 0.15

.XXX ± 0.10

ANG ±

PJECTION

照片框

ORDER INFORMATION

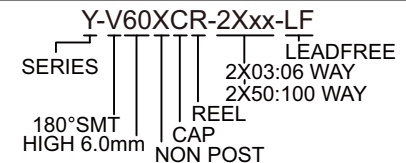

DESCRIPTION:

卷裝收料方向

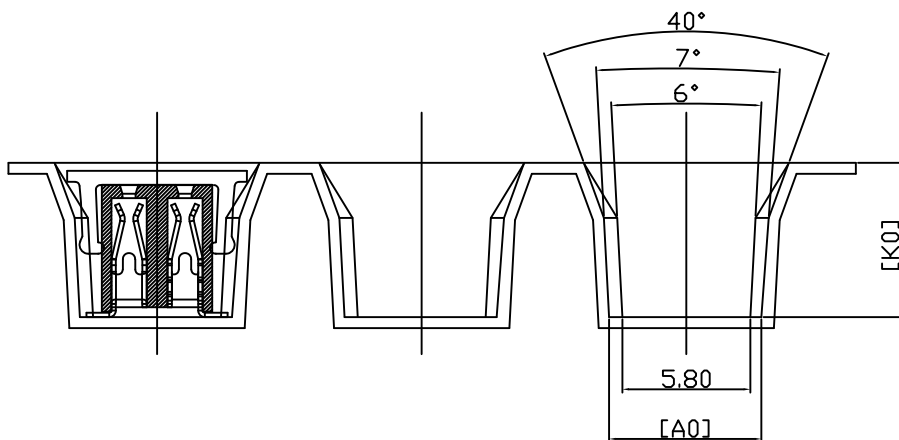
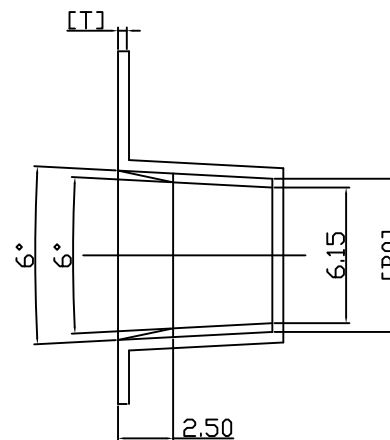
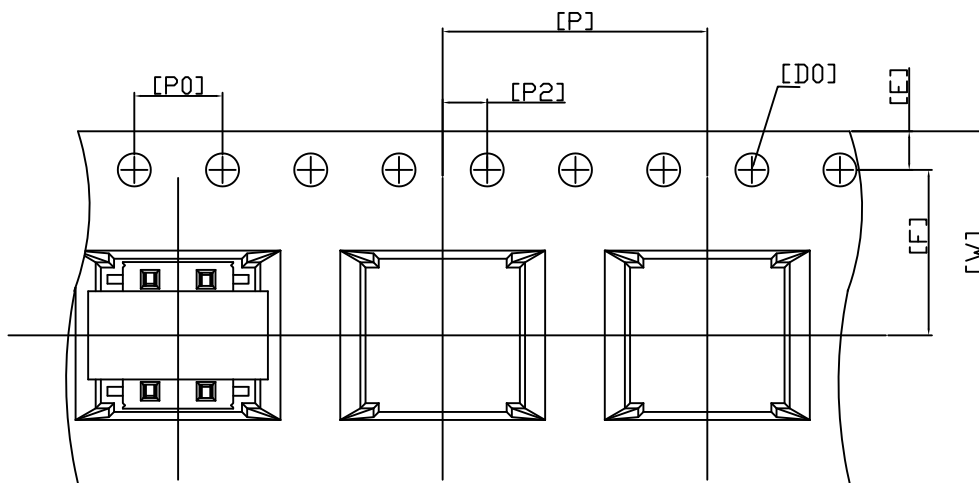

Notes:

1. Packing Conforms EIA-481-C Standards.
2. 10 sprocket hole pitch cumulative tolerance $\pm 0.2\text{mm}$.
3. Carrier camber is within 1mm in 250mm.
4. Material: BLACK Polystyrene.
5. Packing length per 13" Reel: 10.60 Meters.
6. Component load per 13" Reel: 800 PCS.
7. All materials must meet Greenconn requirement for environment protection

W	16.00 $^{+0.30}_{-0.30}$	T	0.50 ± 0.05	Po	4.00 ± 0.10	Ao	7.00 ± 0.15	A1
F	7.50 ± 0.10	Do	$\phi 1.50 \pm 0.10$	P2	2.00 ± 0.10	Bo	6.95 ± 0.10	B1
E	1.75 ± 0.10	P	12.00 ± 0.10	D1		Ko	7.00 ± 0.10	K1

RoHS Compliant

TOLERANCES ARE

MORETHANALL
PCB CONNECTORS
Cable ASSEMBLIES

煜倫股份有限公司

www.morethanall.com

DRAWING BY CY

CHECKED BY GENIUS

UNIT / mm SCALE 1 : 1

DATE

SIZE A4

X. ± 0.30

.X ± 0.25

.XX ± 0.20

.XXX ± 0.15

ANG \pm

P PROJECTION

照片框

ORDER INFORMATION

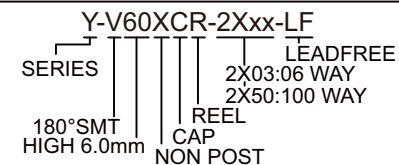

DESCRIPTION: T&R-PACKING 2X05 Pin