

- NOTES:
- MATERIAL:
 - OUTSIDE SHELL: SUS304-1/4H T=0.25mm
 - INNER SHELL: SUS301-1/2H T=0.20mm
 - MID PLATE: SUS301-H T=0.15mm
 - HOUSING: PA9T+45%GF UL94V-0
 - DIP-TERMINARL: C7025 T=0.12mm
 - SMT-TERMINARL: C19400 T=0.12mm
 - PLATING:
 - TERMINAL: SEE PIN
 - SHELL: NICKEL PLATED 50u"MIN.
 - ELECTRICAL CHARACTERISTICS:
 - CURRENT RATING: 5.0 A
 - VOLTAGE RATING: 20.0 V
 - LLCR: VBUS& GND PINS: 40mQ/PIN MAX
OTHER PINS : 40mQ/PIN MAX
LLCR MAX. CHANGE OF ALL PINS: 10mQ
 - INSULATION RESISTANCE: 100MΩ MIN.
 - MECHANICAL CHARACTERISTICS:
 - INSERTION FORCE: 0.5~2.0kg.
 - WITHDRAWAL FORCE: 0.8~2.0kg.(INITIAL) 0.6~2.0kg.(AFTER LIFE TEST)
 - LIFE TEST: 10000 CYCLES MIN

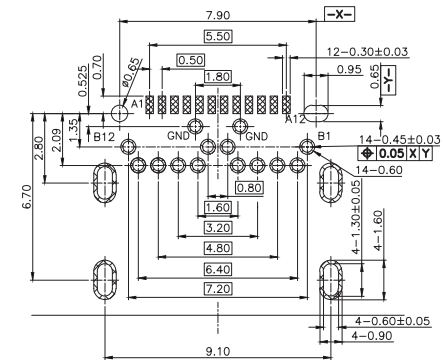

RECOMMENDED PCB LAYOUT(TOP VIEW)
(TOLERANCE=±0.05mm)

USB TYPE-C PIN ASSIGNMENTS:

PIN	SIGNAL NAME	PIN	SIGNAL NAME
A12	GND	B1	GND
A11	SSRXp2	B2	SSTXp2
A10	SSRXn2	B3	SSTXn2
A9	VBUS	B4	VBUS
A8	SBU1	B5	CC2
A7	Dn1	B6	Dp2
A6	Dp1	B7	Dn2
A5	CC1	B8	SBU2
A4	VBUS	B9	VBUS
A3	SSTXn1	B10	SSRXn1
A2	SSTXp1	B11	SSRXp1
A1	GND	B12	GND

RoHS Compliant

TOLERANCES ARE

MORETHANALL
PCB CONNECTORS
Cable ASSEMBLIES

DRAWING BY CY

X. ± 0.40

CHECKED BY GENIUS

.X ± 0.30

UNIT / mm

SCALE 1 : 1

.XX ± 0.15

DATE

.XXX ±

ANG ± 2°

SIZE A4

PJECTION

照片框

ORDER INFORMATION

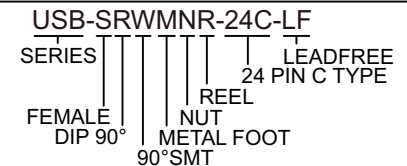

DESCRIPTION:

煜倫股份有限公司

www.morethanall.com

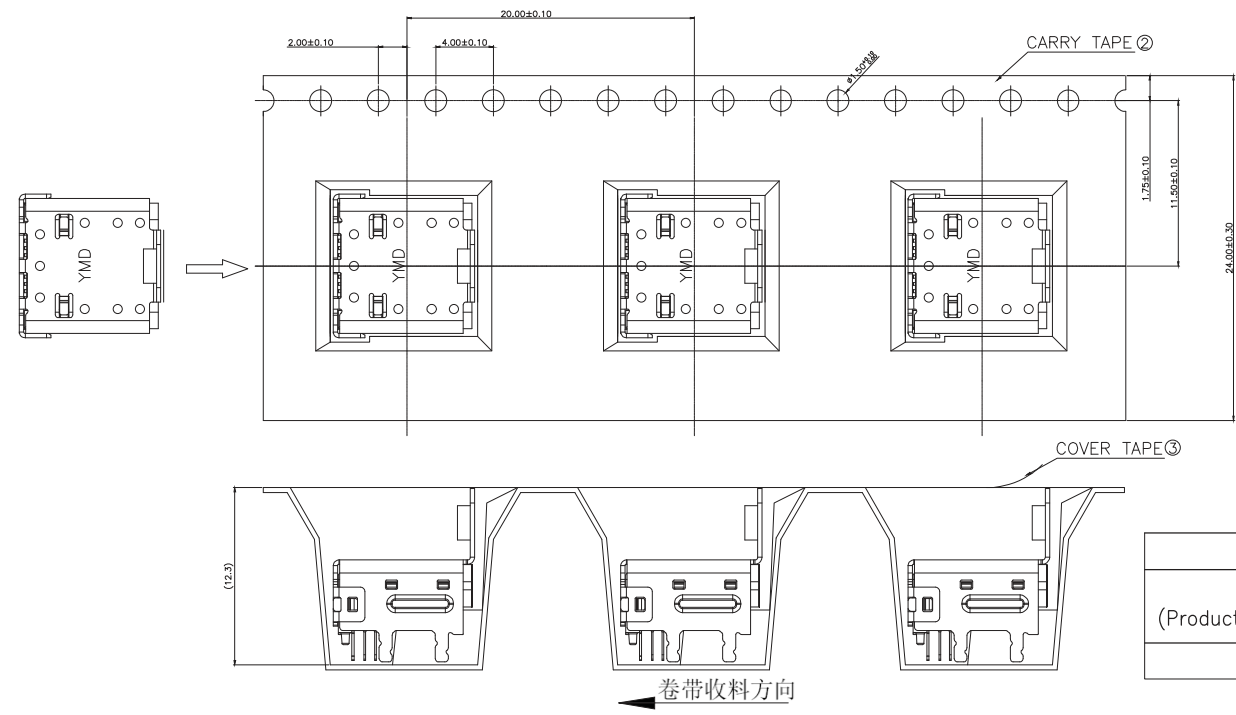
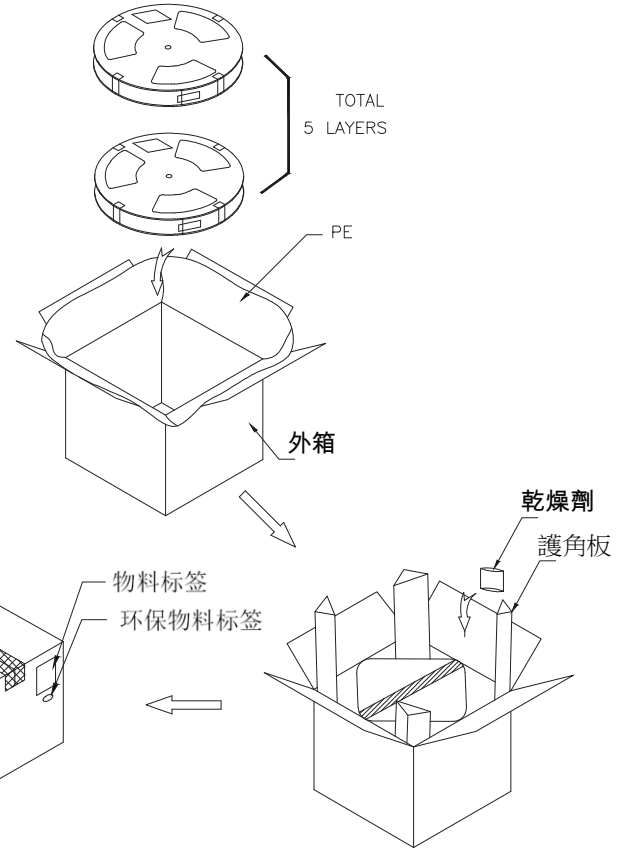
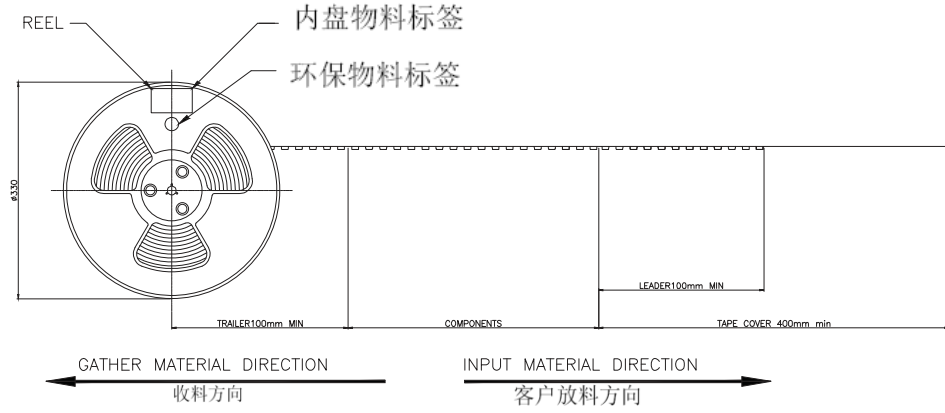

(The detail of the packing)

(Product No.)	(Packing Capacity)			Weight (Kg)		
	pcs/box	boxs/Carton	Pcs/Box	N.W./Pcs	N.W./Box	G.W./Box
	240	5	1200			

RoHS Compliant

TOLERANCES ARE

MORETHANALL
PCB CONNECTORS
Cable ASSEMBLIES
煜倫股份有限公司
www.morethanall.com

DRAWING BY CY		X. ± 0.40
CHECKED BY GENIUS		.X ± 0.30
UNIT / mm	SCALE 1 : 1	.XX ± 0.15
DATE		.XXX ±
SIZE A4	PJECTION	ANG ± 2°



ORDER INFORMATION

USB-SRWMNR-24C-LF
SERIES | | | | | LEADFREE
FEMALE | | | | | 24 PIN C TYPE
DIP 90° | | | | | REEL
NUT | | | | | METAL FOOT
90°SMT

DESCRIPTION: