

NOTE:

1.ELECTRICAL CHARACTERISTICS;

1.1 CONTACT RESISTANCE: 40mΩ Max FOR INITIAL. 50mΩ CHANGE AFTER TEST. MEASURE AT 20mV, 100mA.

1.2 CONTACT CURRENT RATING: 5A FOR VBUS PIN; 1.25A FOR VCONN PIN.

1.3 DIELECTRIC WITHSTANDING VOLTAGE: 100V AC R.M.S.

1.4 INSULATION RESISTANCE 100MΩ Min

1.5 OPERATING TEMPERATURE: -40°C ~ 85°C

2.MECHANICAL CHARACTERISTICS:

2.1 MATING FORCE: 5~20 N.

2.2 UNMATED FORCE: 8~20N AFTER TEST

2.3 DURABILITY: 10,000 CYCLES

4	Shell	1	SUS	T=0.30mm	matte Tin Plated
3	Gnd plates	3	SUS	T=0.15mm	Solder area: matte Tin Plated
2	Contact	24	COPPER ALLOY	T=0.15mm	Contact area: 30u" PD/Ni+Gold Flash Solder area: 80u"min. matte Tin Plated over Nickel
1	Housing	3	THERMOPLASTIC	UL 94-V0	Black
No.	Name	Q'ty	Material	Remarks & Thickness	Finish

RoHS Compliant

TOLERANCES ARE

MORETHANALL
PCB CONNECTORS
Cable ASSEMBLIES

DRAWING BY CY

CHECKED BY GENIUS

UNIT / mm

SCALE 1:1

DATE

SIZE A4

X, ±
.X ± 0.30
.XX ± 0.20
.XXX ± 0.10
ANG ± 1°

PJECTION

照片框

ORDER INFORMATION

USB-SE09L06R-24C-LF
SERIES | REEL | LEADFREE
HIGH 6.5mm
EDGE 0.9mm
FEMALE

DESCRIPTION: USB3.1-C TYPE(F)180°夾式(6.5mm)

煜倫股份有限公司

www.morethanall.com

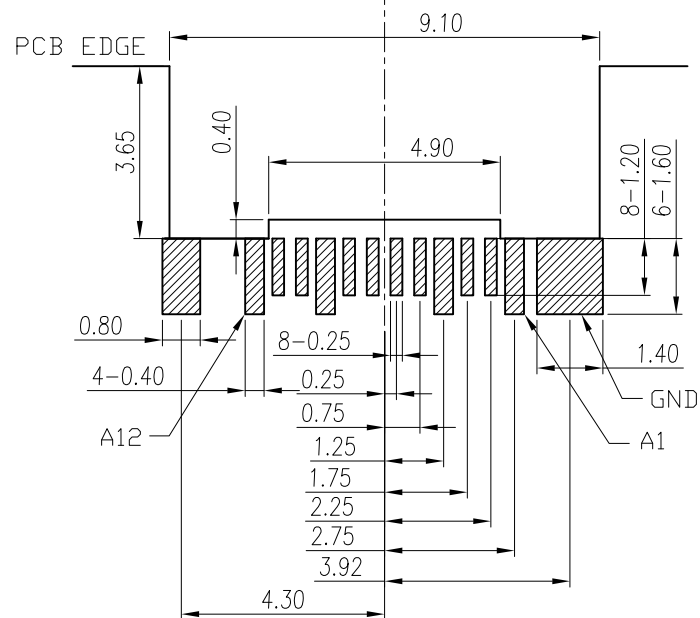
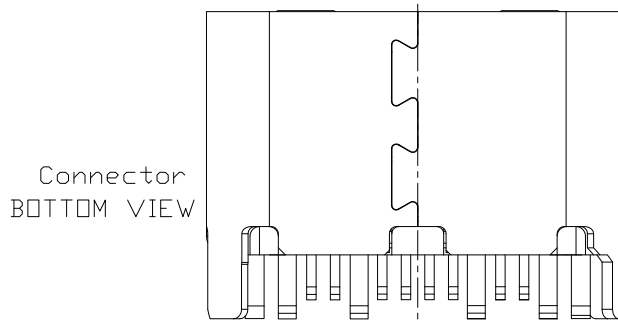
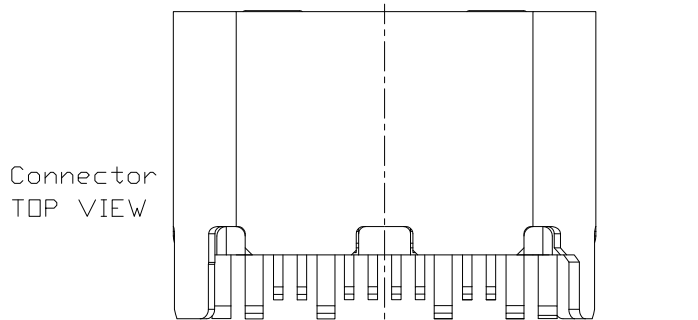

RECOMMEND PCB LAYOUT
TOP VIEW

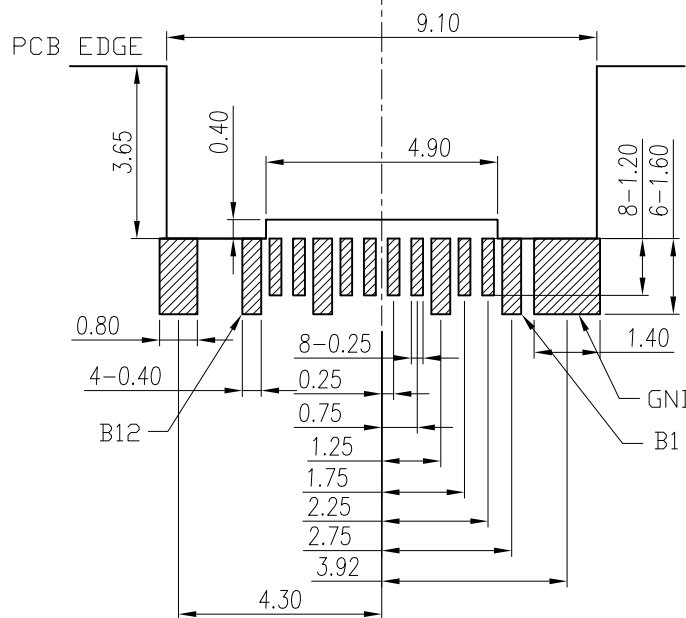

RECOMMEND PCB LAYOUT
BOTTOM VIEW

Pin Assignments

Pin No	Signal Name	Signal Name	Pin No
A1	GND	GND	B12
A2	TX1+	RX1+	B11
A3	TX1-	RX1-	B10
A4	Vbus	Vbus	B9
A5	CC1	SBU2	B8
A6	D+	D-	B7
A7	D-	D+	B6
A8	SBU1	CC2	B5
A9	Vbus	Vbus	B4
A10	RX2-	TX2-	B3
A11	RX2+	TX2+	B2
A12	GND	GND	B1

RoHS Compliant

TOLERANCES ARE

MORETHANALL
PCB CONNECTORS
Cable ASSEMBLIES

DRAWING BY CY

X, ±

CHECKED BY GENIUS

.X ± 0.30

UNIT / mm

SCALE 1 : 1

.XX ± 0.20

DATE

.XXX ± 0.10

ANG ± 1°

SIZE A4

PJECTION

照片框

ORDER INFORMATION

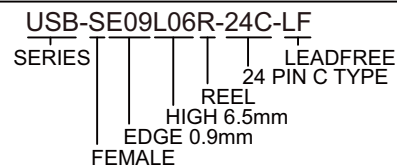

DESCRIPTION: USB3.1-C TYPE(F)180°夾式(6.5mm)

煜倫股份有限公司

www.morethanall.com

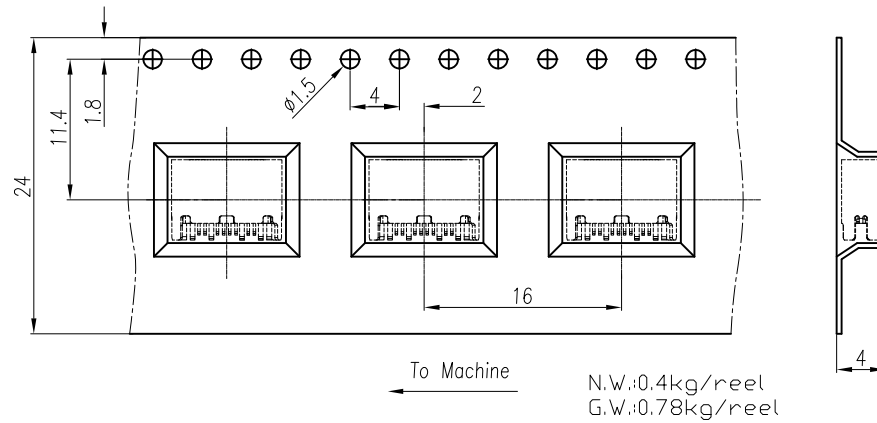

NOTES:

- 1.Material:
 - 1.1 Carrier:Black Anti-Static Polystyrene.
 - 1.2 Shipping carton:corrugated fiberboard
 - 1.3 Waterproofing bag:PE
- 2.Dimension:
 - 2.1 Carrier: Thickness:0.4±0.05mm.
 - 2.2 Disk:Diameter ø330mm.
- 3.Quantity:
 - 3.1 Primary packing:1000 PCS/Disk(16.3 meters).
 - 3.2 Secondary packing:10 Disk(10000PCS).
- 4.Weight:
 - 4.1 Net weight: 4 Kg
 - 4.2 Gross weight:8.9 Kg

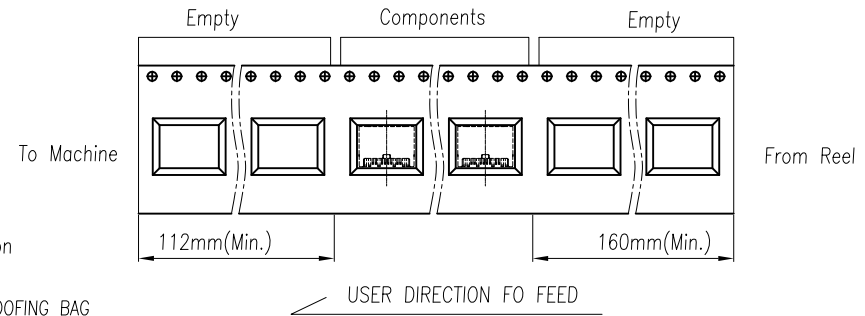
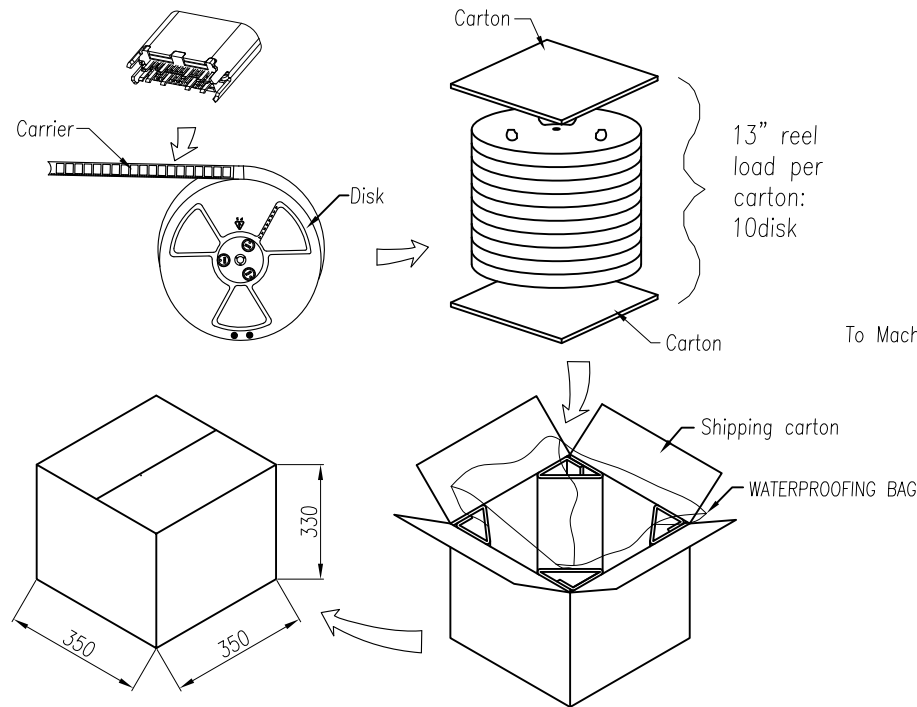

RoHS Compliant

TOLERANCES ARE

MORETHANALL
PCB CONNECTORS
Cable ASSEMBLIES

DRAWING BY CY

CHECKED BY GENIUS

UNIT / mm SCALE 1 : 1

DATE

SIZE A4

X, ±
.X ± 0.30
.XX ± 0.20
.XXX ± 0.10
ANG ± 1°

PPOJECTION

照片框

ORDER INFORMATION

USB-SE09L06R-24C-LF

SERIES REEL LEADFREE
24 PIN C TYPE
HIGH 6.5mm
EDGE 0.9mm
FEMALE

DESCRIPTION: USB3.1-C TYPE(F)180°夾板式(6.5mm)-(平行卷裝)

煜倫股份有限公司

www.morethanall.com