

NOTE:

1.ELECTRICAL CHARACTERISTICS;

1.1 CONTACT RESISTANCE: 40mΩ Max FOR INITIAL. 50mΩ CHANGE AFTER TEST. MEASURE AT 20mV, 100mA.

1.2 CONTACT CURRENT RATING: 5A FOR VBUS PIN; 1.25A FOR VCONN PIN.

1.3 DIELECTRIC WITHSTANDING VOLTAGE: 100V AC R.M.S.

1.4 INSULATION RESISTANCE 100MΩ Min

1.5 OPERATING TEMPERATURE: -40°C~85°C

2.MECHANICAL CHARACTERISTICS:

2.1 MATING FORCE: 5~20N

2.2 UNMATED FORCE: 8~20N

2.3 DURABILITY: 10,000 CYCLES

No.	Name	Q'ty	Material	Remarks & Thickness	Finish
5	Shell	1	SUS	T=0.15mm	60u"min. Nickel Plated
4	EMI Spring	2	SUS	--	No Plated
3	GND LATCH	1	SUS	T=0.35mm	Solder area: matte Tin Plated
2	Contact	24	COPPER ALLOY	T=0.15mm	Contact area: 0~30u" PD/Ni+Gold Flash Solder area: 80u"min. matte Tin Plated over Nickel
1	Housing	3	THERMOPLASTIC	UL 94-V0	Black

RoHS Compliant

TOLERANCES ARE

MORETHANALL
PCB CONNECTORS
Cable ASSEMBLIES

DRAWING BY CY

CHECKED BY GENIUS

UNIT / mm SCALE 1 : 1

DATE

SIZE A4

X, ±
.X ± 0.30
.XX ± 0.20
.XXX ± 0.10
ANG ± 1°

P PROJECTION

照片框

ORDER INFORMATION

USB-PE08R-24C-LF
SERIES | LEADFREE
24 PIN C TYPE
REEL
EDGE CLIP 0.8mm
MALE

DESCRIPTION: USB3.1-C TYPE(M)180°夾板式(銅腳平齊型)

煜倫股份有限公司

www.morethanall.com

Connector
TOP VIEW

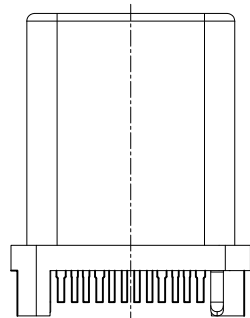

Connector
BOTTOM VIEW

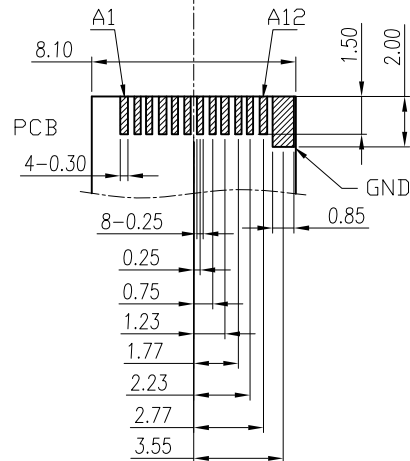
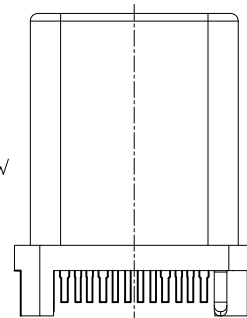

RECOMMEND PCB LAYOUT
TOP VIEW

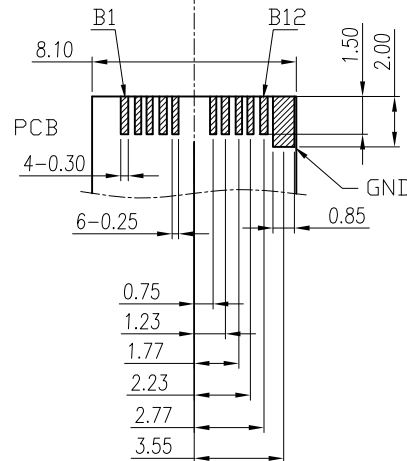

RECOMMEND PCB LAYOUT
BOTTOM VIEW

Pin Assignments

Pin No	Signal Name	Signal Name	Pin No
A1	GND	GND	B12
A2	TX1+	RX1+	B11
A3	TX1-	RX1-	B10
A4	Vbus	Vbus	B9
A5	CC	SBU2	B8
A6	D+		B7
A7	D-		B6
A8	SBU1	Vconn	B5
A9	Vbus	Vbus	B4
A10	RX2-	TX2-	B3
A11	RX2+	TX2+	B2
A12	GND	GND	B1

RoHS Compliant

TOLERANCES ARE

MORETHANALL
PCB CONNECTORS
Cable ASSEMBLIES

DRAWING BY CY

CHECKED BY GENIUS

UNIT / mm

SCALE 1 : 1

DATE

SIZE A4

X, ±
.X ± 0.30
.XX ± 0.20
.XXX ± 0.10
ANG ± 1°

P PROJECTION

照片框

ORDER INFORMATION

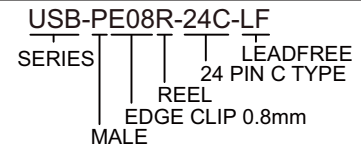

DESCRIPTION: USB3.1-C TYPE(M)180°夾板式(銅腳平齊型)

煜倫股份有限公司

www.morethanall.com

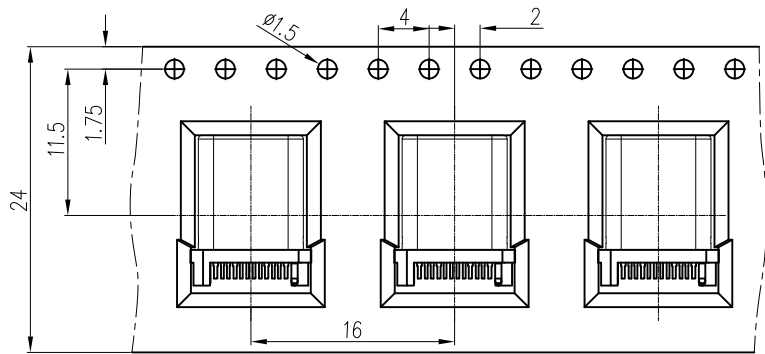

To Machine N.W.:0.6kg/reel
G.W.:0.98kg/reel

NOTES:

- 1.Material:
 - 1.1 Carrier:Black Anti-Static Polystyrene.
 - 1.2 Shipping carton:corrugated fiberboard
 - 1.3 Waterproofing bag:PE
- 2.Dimension:
 - 2.1 Carrier: Thickness:0.4±0.05mm.
 - 2.2 Disk:Diameter ø330mm.
- 3.Quantity:
 - 3.1 Primary packing:1000 PCS/Disk(16.3 meters).
 - 3.2 Secondary packing:10 Disk(10000PCS).
- 4.Weight:
 - 4.1 Net weight:6 Kg
 - 4.2 Gross weight:10.9 Kg

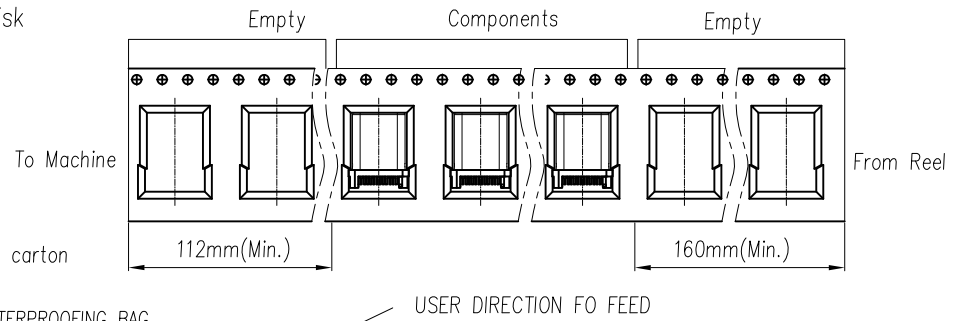
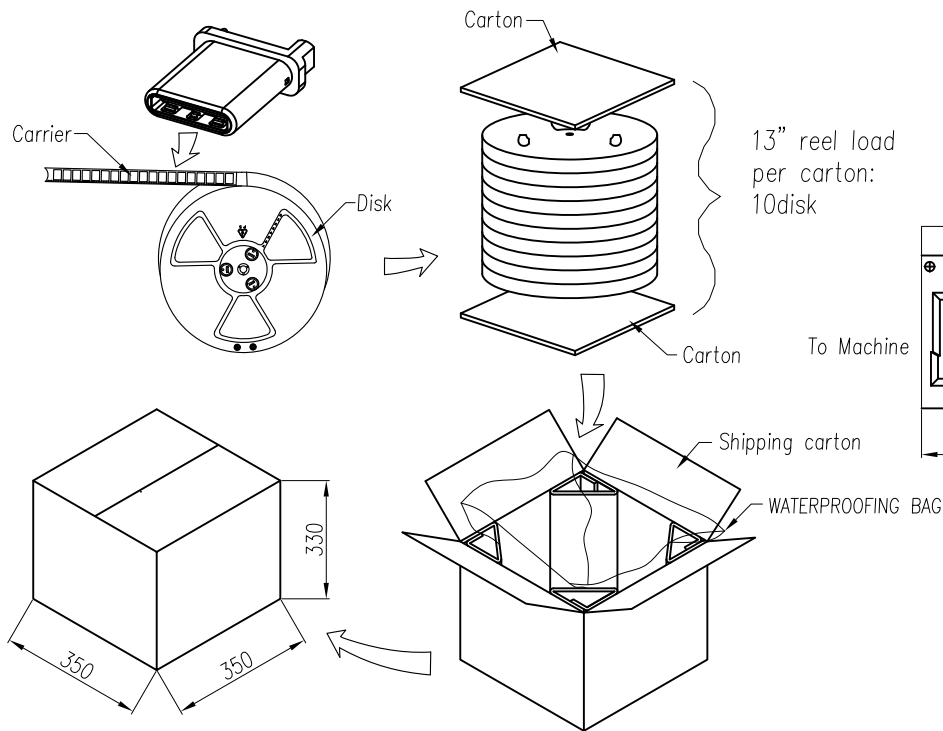

RoHS Compliant

TOLERANCES ARE

MORETHANALL
PCB CONNECTORS
Cable ASSEMBLIES

DRAWING BY CY
CHECKED BY GENIUS
UNIT / mm SCALE 1 : 1
DATE

X, ±
.X ± 0.30
.XX ± 0.20
.XXX ± 0.10
ANG ± 1°

照片框

ORDER INFORMATION

USB-PE08R-24C-LF
SERIES REEL EDGE CLIP 0.8mm
LEADFREE
24 PIN C TYPE
MALE

煜倫股份有限公司

www.morethanall.com

SIZE A4 PPROJECTION

DESCRIPTION: USB3.1-C TYPE(M)180°夾板式(卷裝)