

(N= NUMBER OF POLES)

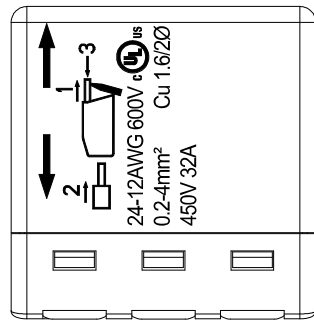
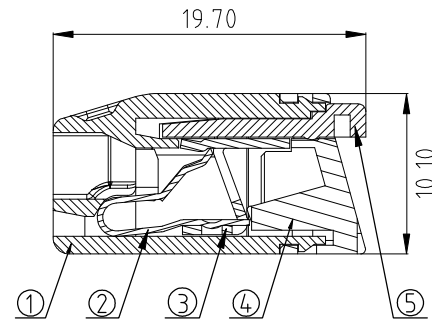

Electrical

- Voltage rating: UL 600V (IEC 450V)
- Current rating: UL 35A (IEC 32A)
- Wire range: 0.2-4mm²
- Solid wire(AWG): 12-24
- Stranded wire(AWG): 12-24
- Wire strip length: 11-12mm
- Withstanding Voltage: 3.4KV
- Insulation resistance: 500MΩ @DC500V
- Operating temperature: -40 to +85°C
- Safety Approval: cULus
- Poles: 2P, 3P, 5P

Material

- Item ① Terminal housing: PC
- Item ② Terminal Clamp: Stainless steel
- Item ③ Conductor: Copper
- Item ④ Terminal Cover: PC
- Item ⑤ Terminal lever: PA66

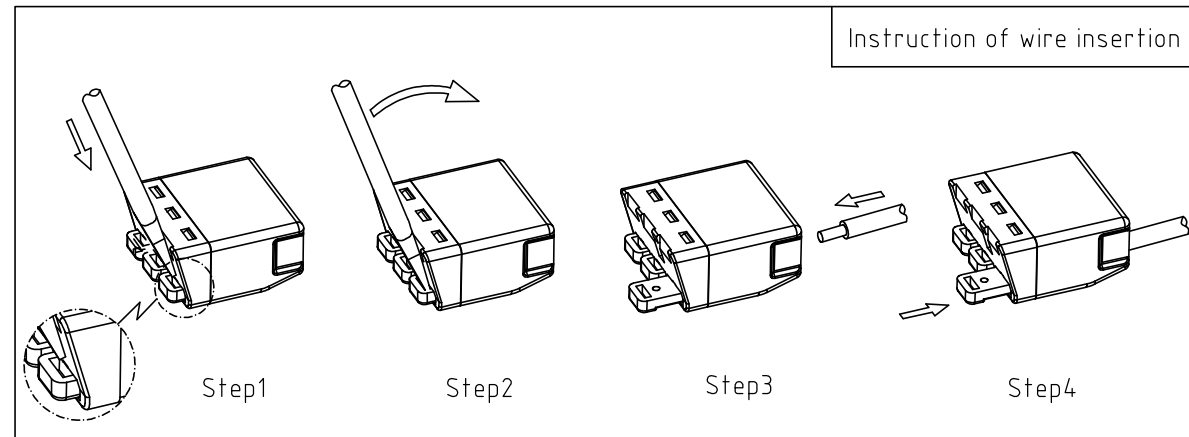

RoHS Compliant

TOLERANCES ARE

MORETHANALL
PCB CONNECTORS
Cable ASSEMBLIES
煜倫股份有限公司

DRAWING BY CY

X. ± 0.50

CHECKED BY GENIUS

.X ± 0.30

UNIT / mm

SCALE 1 : 1

.XX ± 0.10

DATE

.XXX ±

ANG ± 1°

SIZE A4

PJECTION

照片框

ORDER INFORMATION

TBY056-W-xx-LF

SERIES

LEADFREE

02.03.05 WAY

WIRE TO WIRE

www.morethanall.com

DESCRIPTION: Pitch5.60 2P/3P/5P 本體透明(PC) 壓板橙色(NL66)