

ITEM 項目	PARTS NAME 零件名稱	Q'TY 數量	MATERIAL 材質	FINISH/REMARK 處理/備註
1	SHELL	1	SUS 304	50u" NICKEL,100u" TIN
2	CONTACT	20	Phosphor Bronze	Contact Area:15u" Gold Flash Plating 1~3u" Gold Flash Over All
3	HOUSING	1	L.C.P	(Black)

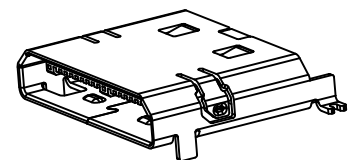
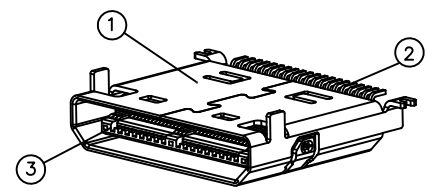

SPECIFICATION
 MATERIAL
 See drawing
 STANDARD DATA
 Rating current: 0.5A
 Working voltage: DC 3V
 ELECTRICAL
 Insulator resistance: 1000M ohms Min. @ 250 VDC
 Withstanding voltage: 250 VAC / minute
 Contact resistance: 60 m ohms Max.
 MECHANICAL
 Mating force: 30N(3.06kgf) Max.
 Unmating force (Without lock): 4.2N(0.43kgf) Min.
 Durability: 10000 cycles Min.
 Contact retention force: 4.2N(0.43kgf) Min

MSB-SWR-20-LF
 LEADFREE
 RoHS Compliant

	PART NO. MSB-SWR-20		CHECKED BY CY	TOLERANCES ARE .X± .XX± .XXX± AWG	DESCRIP TION: I/O CONNECTOR SMT TYPE-20 position		
	DWG NO. MSB-SWR-20					DRAWING BY	
	FILE NO.		PROJECTION	AREA	REVISIONS	HK	DATE
	UNIT / mm	SCALE 1:1					

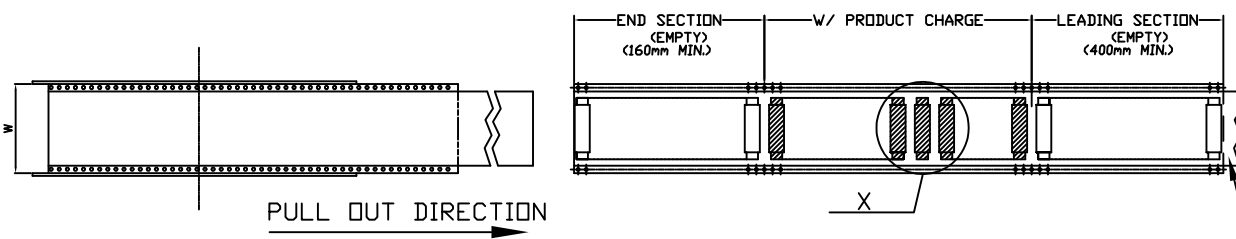

ITEM 項目	PARTS NAME 零件名稱	FINISH/REMARK 處理/備註
1	I/O CONNECTOR	--
2	BOX	12PCS REEL/BOX
3	WATERPROOF BAG	1 PCS
4	REEL	800PCS/REEL
5	COVER TAPE	Wide=24mm
6	CARRIER TAPE	--
7	LABEL	批號標籤

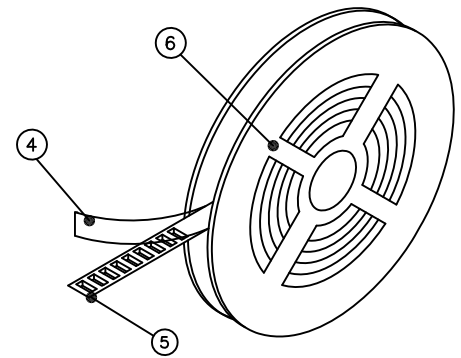
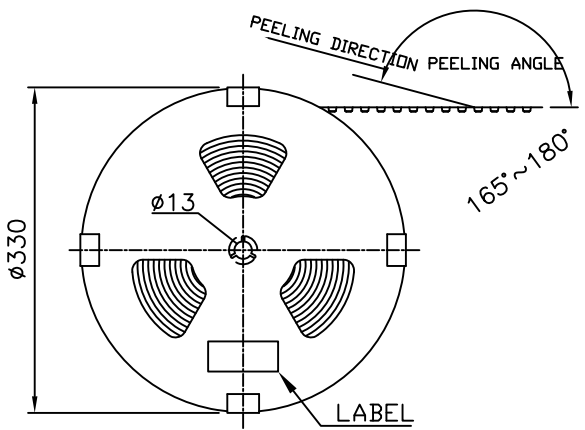

TOP COVER TAPE

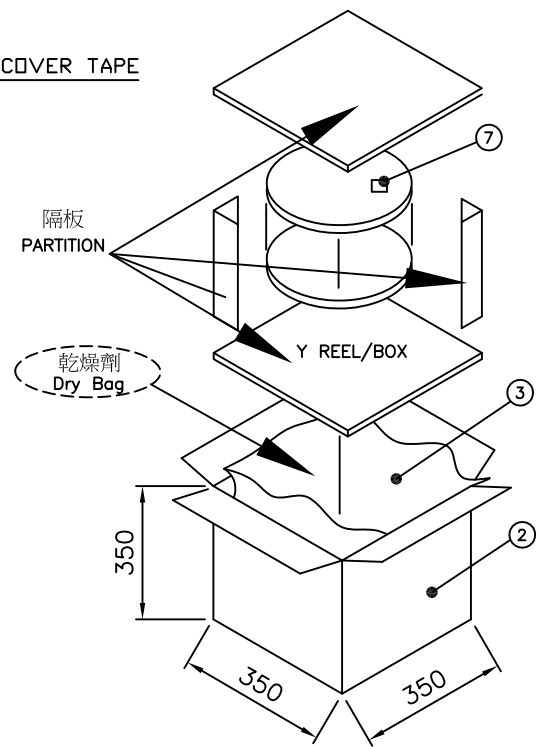

收料方向
CATHETER MATERIAL
DIRECTION

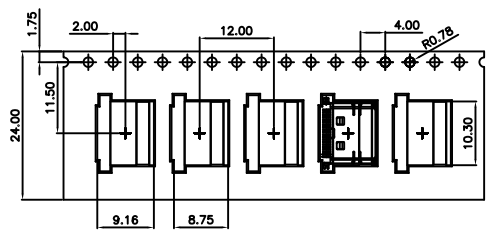

客戶放料方向
INPUT MATERIA
DIRECTION

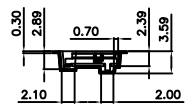

NOTES
 1.MATERIAL: PS (Color: 黑色)
 2.DEFORMATION(變形)&DAMAGE(損壞): NA.(不可)
 3.All dimensions meet EIA-481-C requirements.

MORETHANALL
CONNECTORS
ASSEMBLIES

煜倫股份有限公司

PART NO. MSB-SWR-20

DWG NO. MSB-SWR-20

FILE NO.

UNIT / mm

SCALE 1:1

CHECKED BY CY

DRAWING BY

PROJECTION

TOLERANCES ARE

.X ±
.XX ±
.XXX ±
AWG

DESCRIP TION:

AREA	REVISIONS	HK	DATE