

PCB Layout
(Top View)

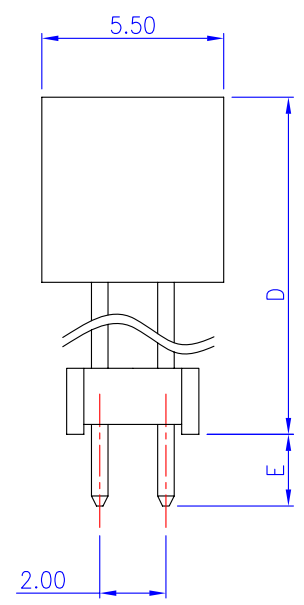
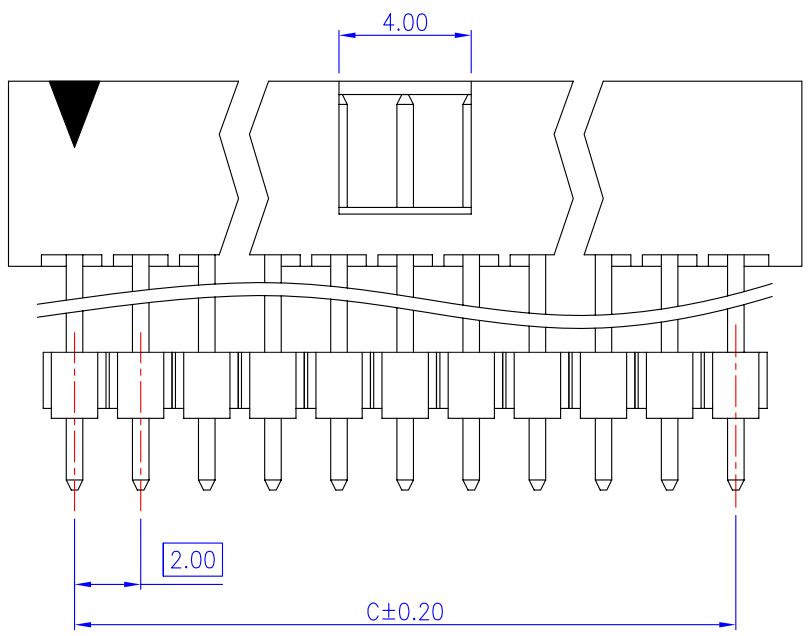

Material and Finish

1. Housing: Thermoplastic (UL94V-0), Black.
2. Terminal: Sq. 0.50mm Copper Alloy, Gold Plating

Electrical Characteristics

1. Current Rating: 1.0 Amp. Max..
2. Dielectric Withstand Voltage: 800V AC RMS for 60Seconds.
3. Insulation Resistance: 1000M Ohms Min. at 500V DC.

Mechanical Characteristics

1. Operating Temperature: -55°C ~ +105°C

RoHS Compliant

TOLERANCES ARE

MORETHANALL
PCB CONNECTORS
Cable ASSEMBLIES
煜倫股份有限公司
www.morethanall.com

DRAWING BY CY		X. ± .X ± .XX ± .XXX ± ANG ±
CHECKED BY GENIUS		
UNIT / mm	SCALE 1 : 1	
DATE		
SIZE A4	PJECTION	



ORDER INFORMATION

MPVKS-D126023-2Xxx-LF			
SERIES			LEADFREE
			2X03:06WAY
			2X34:68WAY
			DIP 2.29mm
			HIGH 12.6mm
			DIP 180°

DESCRIPTION: 2.00mm Box Header Elevate Type PCB Mount Vertical

Length Options				
Code	D	E	Date	Note
01	11.30	2.80	Nov. 09, 2006	
02	17.53	6.17	Feb. 04, 2010	
03				
04				
05				
06				
07				
08				
09				
10				
11				
12				
13				
14				
15				
16				
17				
18				
19				
20				
21				
22				

Length Options			
Pos	A	B	C
06	8.00	6.85	4.00
08	10.00	8.85	6.00
10	12.00	10.85	8.00
12	14.00	12.85	10.00
14	16.00	14.85	12.00
16	18.00	16.85	14.00
18	20.00	18.85	16.00
20	22.00	20.85	18.00
22	24.00	22.85	20.00
24	26.00	24.85	22.00
26	28.00	26.85	24.00
28	30.00	28.85	26.00
30	32.00	30.85	28.00
32	34.00	32.85	30.00

Length Options			
Pos	A	B	C
34	36.00	34.85	32.00
36	38.00	36.85	34.00
38	40.00	38.85	36.00
40	42.00	40.85	38.00
44	46.00	44.85	42.00
46	48.00	46.85	44.00
48	50.00	48.85	46.00
50	52.00	50.85	48.00
54	56.00	54.85	52.00
56	58.00	56.85	54.00
60	62.00	60.85	58.00
62	64.00	62.85	60.00
64	66.00	64.85	62.00
68	70.00	68.85	66.00



PART NO. MPVKS-Dxxx-2Xxx

DWG NO. MPVKS-Dxxx-2Xxx

FILE NO.

UNIT / mm

SCALE 1:1

CHECKED BY CY

DRAWING BY

PROJECTION

TOLERANCES ARE

X. ±
.X ±
.XX ±
.XXX ±
ANG

DESCRIPTION:			
	AREA	REVISIONS	DATE

煜倫股份有限公司