

MATERIAL:
 INSULATOR: L.C.P.+30% GLASS REINFORCED , UL94 V-0
 CONTACT: PHOSPHOR BRONZE , C5210R-SH
 PLASTIC: NYLON 6T+30% GLASS REINFORCED , UL94 V-0
 METAL: STAINLESS STEEL, JIS SUS304-3/4H
 CONTACT PLATING: 3u" and 15u" GOLD PLATING ON CONTACT AREA
 RoHS COMPLIANT

MORETHANALL
 CONNECTORS
 ASSEMBLIES

PART NO. MPC1-W39-124

DWG NO. MPC1-W39-124

CHECKED BY CY

TOLERANCES ARE

DESCRIPTION:

FILE NO.

DRAWING BY

.X ± 0.2

.XX ± 0.1

.XXX ±

AWG

AREA

REVISIONS

HK

DATE

煜倫股份有限公司

UNIT / mm

SCALE 1:1

PROJECTION

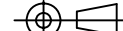

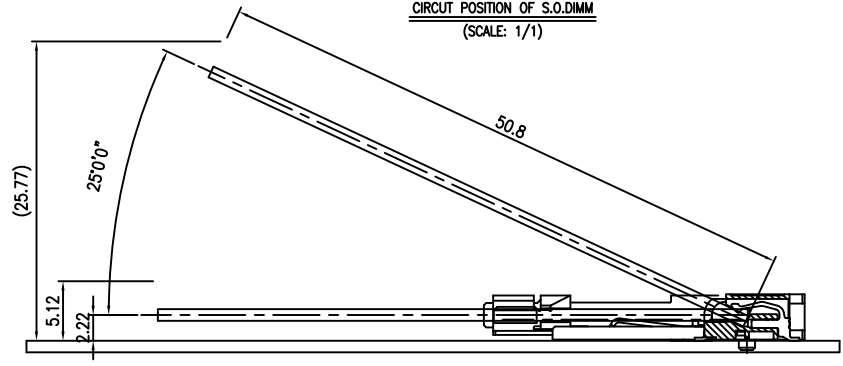
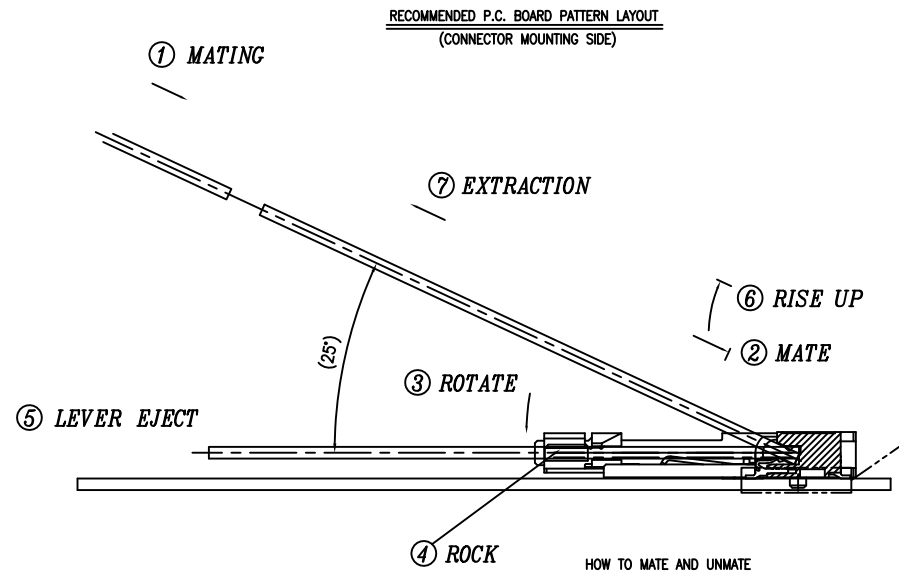
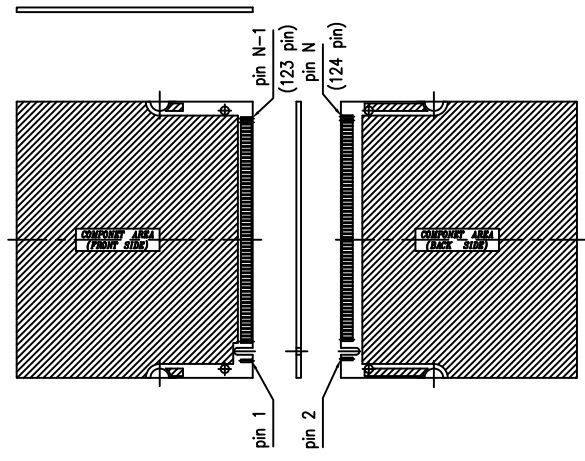
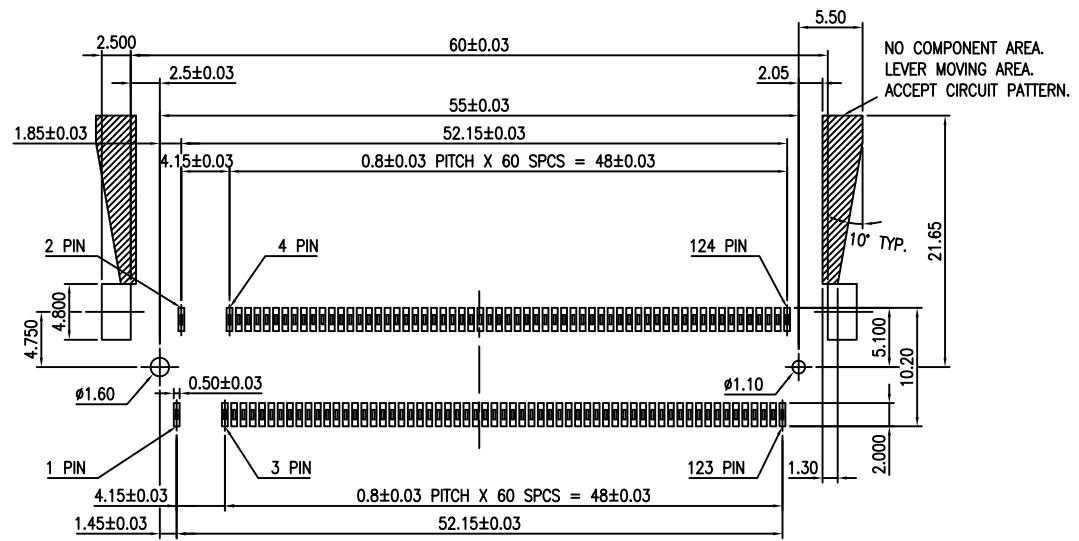

MORETHANALL
CONNECTORS
ASSEMBLIES

PART NO. MPC1-W39-124

DWG NO. MPC1-W39-124

CHECKED BY CY

TOLERANCES ARE

DESCRIP TION:

FILE NO.

DRAWING BY

.X ± 0.2

.XX ± 0.1

.XXX ±

AWG

AREA

REVISIONS

HK

DATE

煜倫股份有限公司

UNIT / mm

SCALE 1:1

PROJECTION

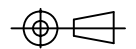

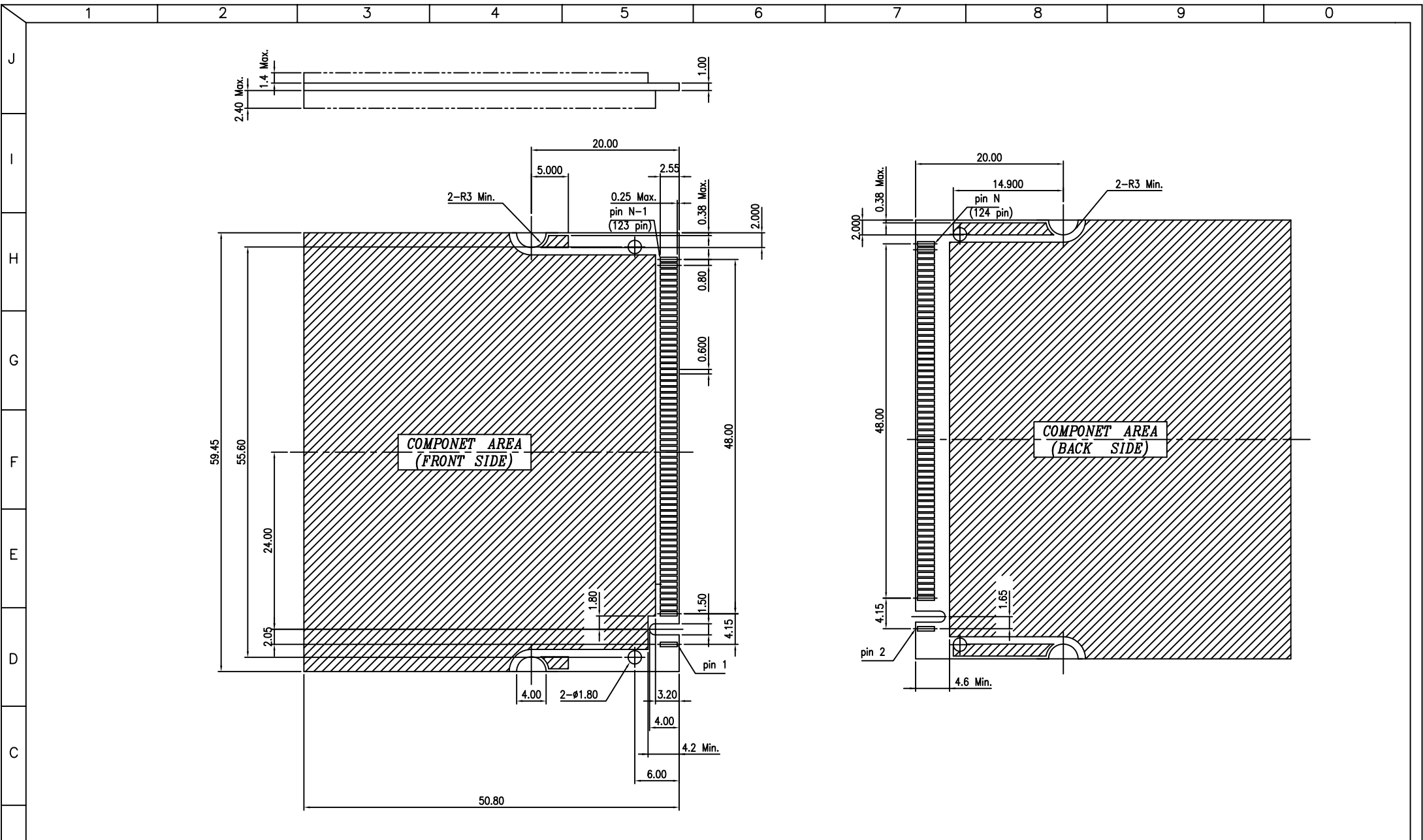

MORETHANALL
CONNECTORS
ASSEMBLIES

PART NO. MPC1-W39-124

DWG NO. MPC1-W39-124

CHECKED BY CY

TOLERANCES ARE

DESCRIP TION:

FILE NO.

DRAWING BY

.X ± 0.2
.XX ± 0.1
.XXX ±
AWG

煜倫股份有限公司

UNIT / mm

SCALE 1:1

PROJECTION

AREA

REVISIONS

HK

DATE