

PICK & PLACE AREA $\phi 3.2$

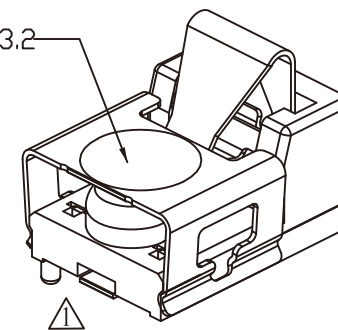

PRODUCT NO.	ITEM	PART NAME	Q'TY	MATERIAL	PLATING
MPCI-LB40R-052	1	BODY	1	LCP	
	2	LATCH	1	PHOSPHOR BRONZE	TIN 100u"
	3	COVER	1	STAINLESS	N/A

RoHS Compliant

TOLERANCES ARE

MORETHANALL
PCB CONNECTORS
Cable ASSEMBLIES

DRAWING BY CY

X, ±

CHECKED BY GENIUS

.X ± 0.25

UNIT / mm

SCALE 1:1

.XX ± 0.20

DATE

.XXX ±

ANG ±

SIZE A4

PJECTION

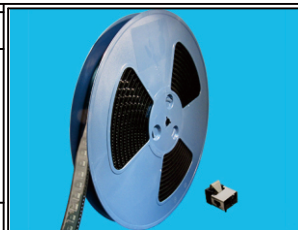

ORDER INFORMATION

MPCI-LB40R-052-LF

SERIES LEADFREE
52 WAY
REEL
HIGH 4.0mm
BRACKET
LATCH

煜倫股份有限公司

www.morethanall.com

DESCRIPTION: MINI PCI EXPRESS CONNECTOR H=4.0mm

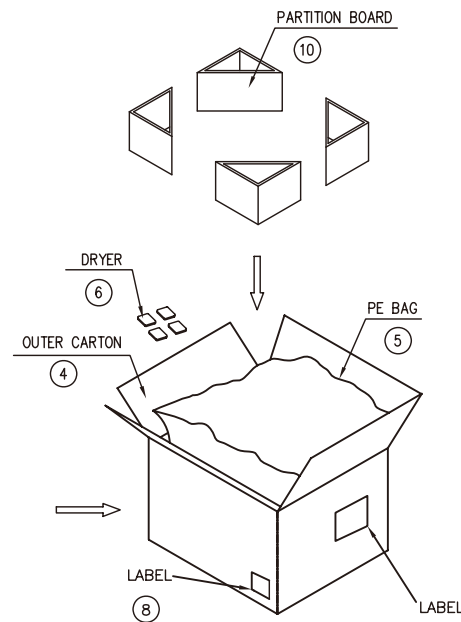
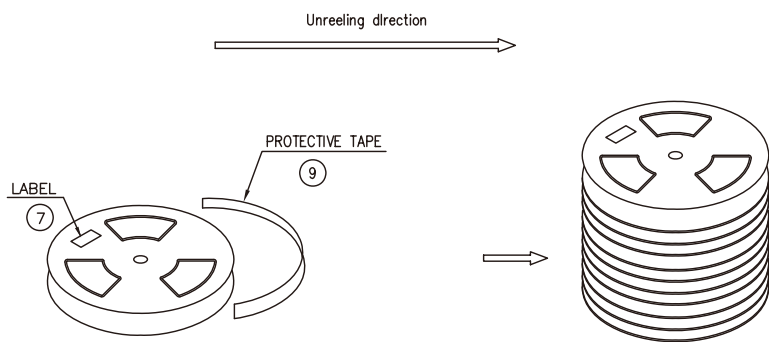
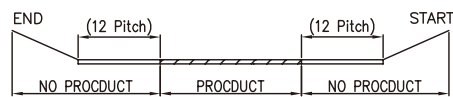
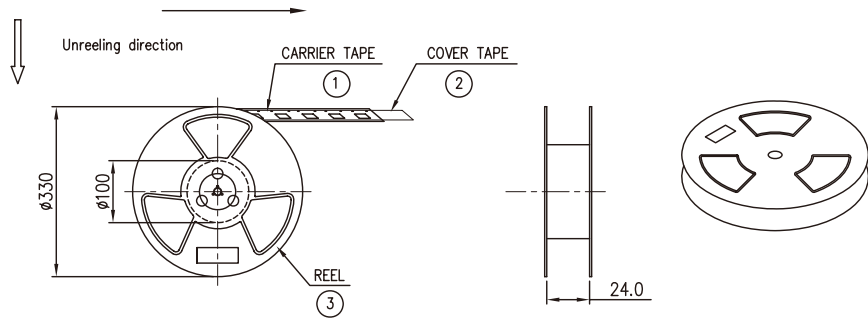
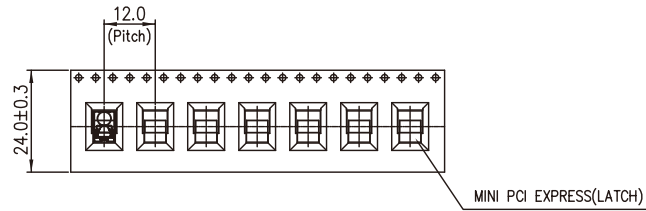

NOTES:

- PACKING STYLE 40 (4.0H)
700 PCS/REEL
7000 PCS/OUTER CARTON
- MATERIAL CARRIER TAPE: PS BLACK
COVER TAPE: PET FILM
REEL: PLASTIC
- PEEL STRENGTH OF COVER TAPE: 20-80g (PEEL SPEED 300mm/MINUTE).

10	PARTITION BOARD	4	PCS		
9	PROTECTIVE TAPE	3	PCS		
8	LABEL	1	PCS		
7	LABEL	6	PCS		
6	DRYER	4	BAG		
5	PE BAG	1	PCS	L850*W750mm	
4	OUTER CARTON	1	PCS		
3	REEL	10	SET	Ø330*100mm, W=44mm	
2	COVER TAPE	SEE NOTES	10	PCS	W=21.5mm
1	CARRIER TAPE	SEE NOTES	10	PCS	W=24mm, T=0.5mm
NO	PACKING NAME	PCS/R/R/BOX	UNIT	NOTE	
		PACKING QTY			

RoHS Compliant

TOLERANCES ARE

MORETHANALL
PCB CONNECTORS
Cable ASSEMBLIES

煜倫股份有限公司

www.morethanall.com

DRAWING BY CY

CHECKED BY GENIUS

UNIT / mm SCALE 1 : 1

DATE

SIZE A4

PJECTION

X, ±
.X ± 0.25
.XX ± 0.20
.XXX ±
ANG ±

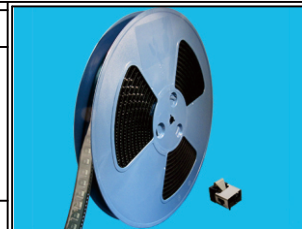

ORDER INFORMATION

MPCI-LB40R-052-LF

SERIES
LEADFREE
52 WAY
REEL
HIGH 4.0mm
BRACKET
LATCH

DESCRIPTION: MINI PCI EXPRESS LATCH

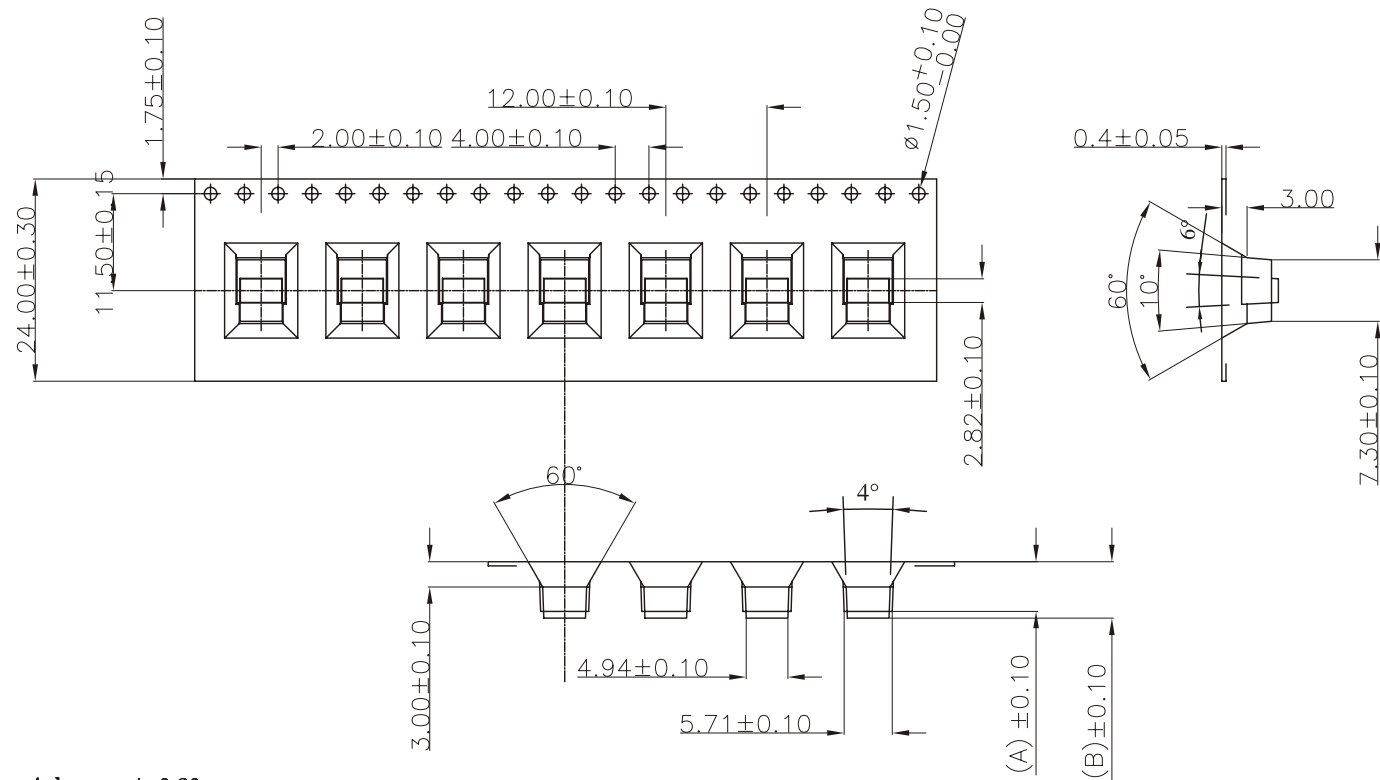

NOTES:

1. 10 sprocket hole pitch cumulative tolerance ± 0.20 mm.
2. Carrier camber not to exceed 1mm in 100 mm.
3. All scope meet EIA-481-C requirements.
4. Material: Black Anti-static Polystyrene.
5. Thickness: 0.40 ± 0.05 mm.

DIM.	40	52	56	80	92
A	5.90	7.10	7.50	9.90	11.10
B	6.70	7.90	8.30	10.70	11.90

RoHS Compliant

TOLERANCES ARE

MORETHANALL
PCB CONNECTORS
Cable ASSEMBLIES

DRAWING BY CY

CHECKED BY GENIUS

UNIT / mm

SCALE 1 : 1

DATE

SIZE A4

PJECTION

X. \pm
.X ± 0.25
.XX ± 0.20
.XXX \pm
ANG \pm

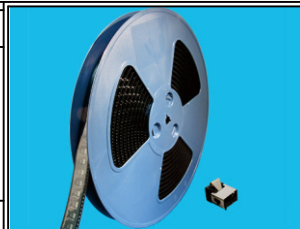

ORDER INFORMATION

MPCI-LB40R-052-LF

SERIES | | | | LEADFREE
| | | | 52 WAY
| | | | REEL
| | | | HIGH 4,0mm
| | | | BRACKET
| | | | LATCH

DESCRIPTION: MINI PCI EXPRESS LATCH

煜倫股份有限公司

www.morethanall.com