

NOTES:
 1. MATERIAL:
 INSULATOR: HIGH TEMPERATURE THERMOPLASTIC,
 UL94V-0, BLACK
 CONTACT: PHOSPHOR BRONZE
 2. PLATING:
 CONTACT AREA: 10 μ m Au Plated OVER Ni
 SOLDER AREA: Tin Plated OVER Ni

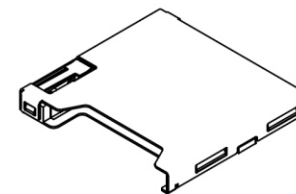
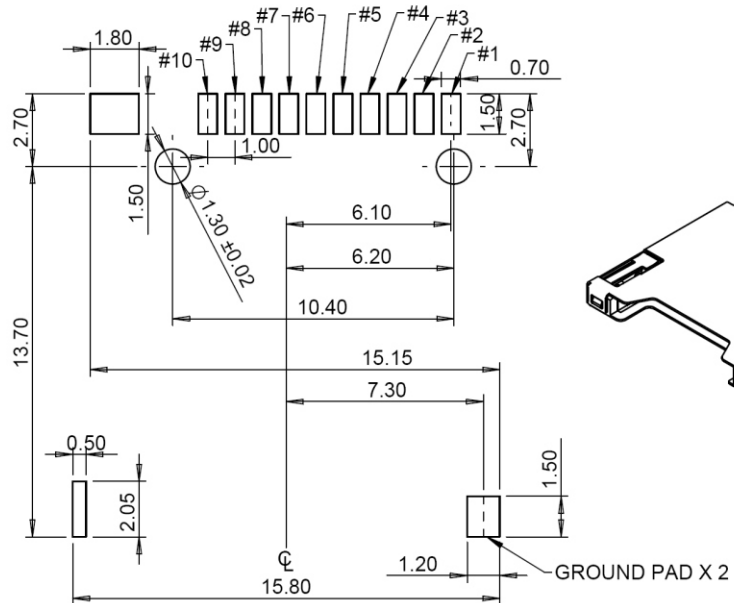

Pin Assignment:	
#1	DTA2
#2	DAT3
#3	CMD
#4	CD
#5	VDD ₁
#6	VDD ₂
#7	CLK
#8	VSS ₂
#9	DAT0
#10	DAT1

WITHOUT CARD	MMCmicro CARD INSERTED
CD ○ ○ GROUND	CD ○ — — — ○ GROUND

MMCM-WPBP-10-LF
LEADFREE

RoHS Compliant

MORE THAN ALL
CONNECTORS
ASSEMBLIES

PART NO. MMCM-WPBP-10

DWG NO. MMCM-WPBP-10

FILE NO.

UNIT / mm

SCALE 1:1

CHECKED BY CY

DRAWING BY

PROJECTION

TOLERANCES ARE

.X ± 0.2
.XX ± 0.1
.XXX ±
AWG

DESCRIPTION:

MMCmicro Push-Push Connector

AREA

REVISIONS

HK

DATE

煜倫股份有限公司