

**PCB LAYOUT**  
( Top View )

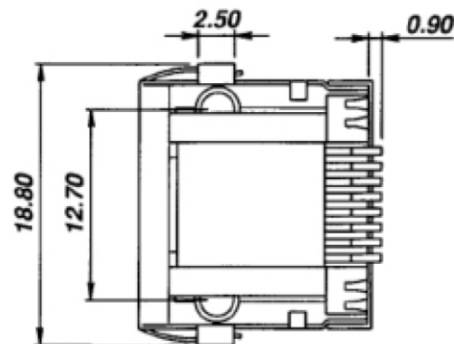

**SPECIFICATION :**

**1. Electrical Char.**

- Insulation Resistance : 500M-Ohm Min.
- Contact Resistance : 20milli-Ohm Max.
- Rating Current : 1.5A Max.
- Rating Voltage : 120V AC.
- Delectric Voltage : 1,000 Vrms 60 Sec. Min.

**2. Physical char.**

- Housing : Nylon (UL 94V-0)
- Color : Black Color
- Spring Wire : 0.35mm Thickness Phosphor Bronze
- Gold Plating Over Nickel
- Temperature Range : - 25 /+90 Deg C

**RoHS Compliant**

TOLERANCES ARE

**MORETHANALL**  
PCB CONNECTORS  
Cable ASSEMBLIES

DRAWING BY CY

CHECKED BY GENIUS

UNIT / mm SCALE 1 : 1

DATE

SIZE A4

X. ±  
.X ±  
.XX ±  
.XXX ±  
ANG ±

P PROJECTION

照片框

ORDER INFORMATION

MJWF13U-KF06EP1R-0808-LF

SERIES | REEL | LEADFREE  
BLACK | 06u" GOLD | 8P8C  
FULL SPRING | EAR+POST

DESCRIPTION:

煜倫股份有限公司

www.morethanall.com

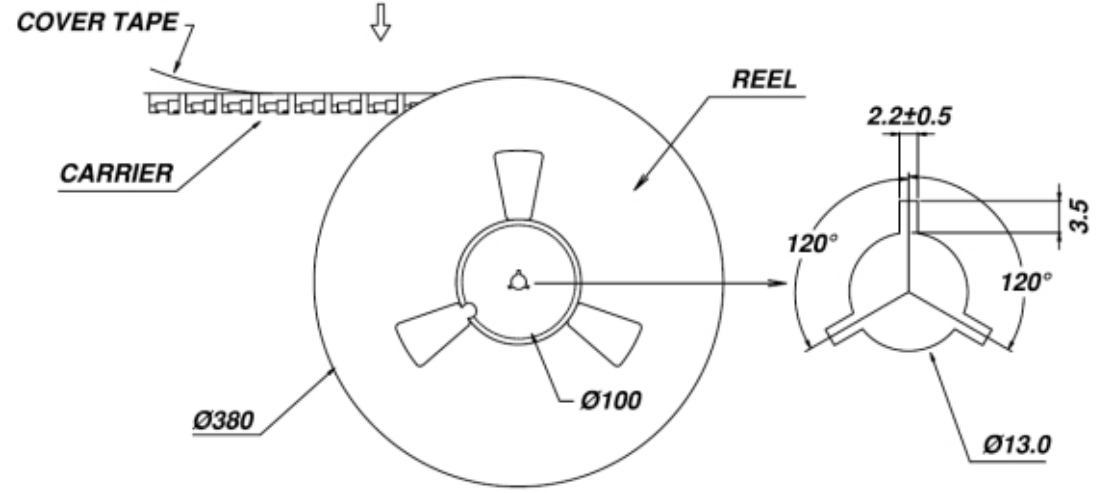
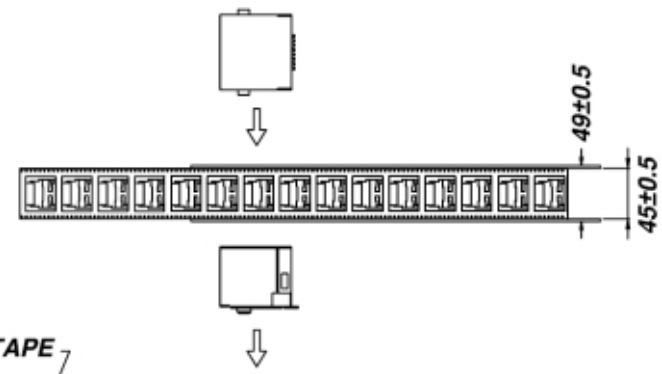
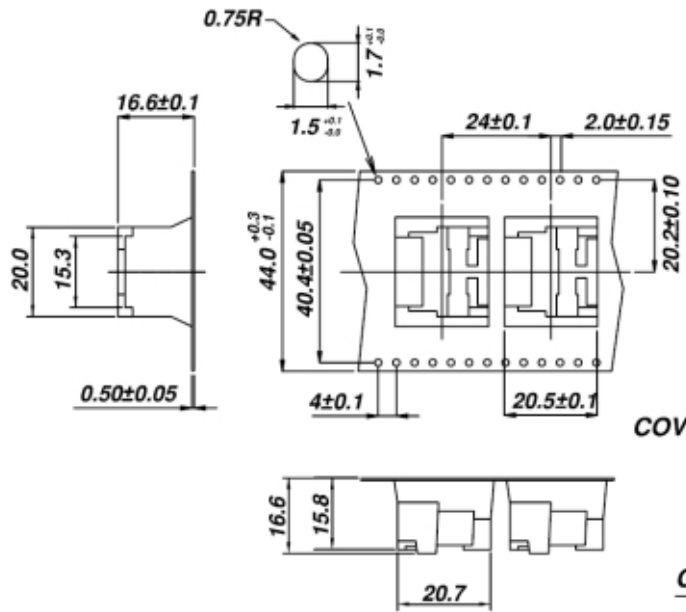

**MATERIALS:**

- REEL-2mm THICK PLASTIC WHEEL.
- CARRIER-PS (0.50mm THICK TAPE).
- COVER TAPE-PE (0.045-0.12mm THICK TAPE).

**NOTES:**

- A. THE DIRECTION OF JACKS PUT INTO CARRIER.
- B. 10 EMPTY CAVITIES FOR BOTH OF TOP AND BOTTOM OF THE CARRIER.
- C. 200 PCS PRODUCTS BE PACKAGED ONE REEL.
- D. CARTON SIZE: 395(L)X390(W)X315(H)  
6 REEL/CARTON  
TOTAL: 1200 PCS

RoHS Compliant

TOLERANCES ARE

**MORETHANALL**  
PCB CONNECTORS  
Cable ASSEMBLIES

DRAWING BY CY

X, ±

CHECKED BY GENIUS

.X ±

UNIT / mm

SCALE 1 : 1

.XX ±

DATE

.XXX ±

ANG ±

煜倫股份有限公司

www.morethanall.com

SIZE A4

P PROJECTION

照片框

ORDER INFORMATION

MJWF13U-KF06EP1R-0808-LF

SERIES

BLACK

REEL

LEADFREE

06u" GOLD

EAR+POST  
FULL SPRING

DESCRIPTION: