

- MATERIAL:
- HOUSING—PA9T GN2330
HEAT RESISTANT PLOYAMIDE RESIN
BLACK COLOR, UL94V-0
 - INSERT HOUSING—DSM STANYL TE250F6 (NYLON-46)
HEAT DEFLECTION TEMP.290°
BLACK COLOR, UL94V-0.
 - CONTACTS—0.35mm THICK PHOS-BRONZE
PLATED WITH HARD GOLD AND
GOLD FLASH IN SOLDER AREA.
 - HOLD DOWN—0.30mm THICK COPPER ALLOY,
PLATED WITH TIN.
- CAVITY CONFIRMS TO FCC RULES AND REGULATIONS
PART 68,SUBPART F.

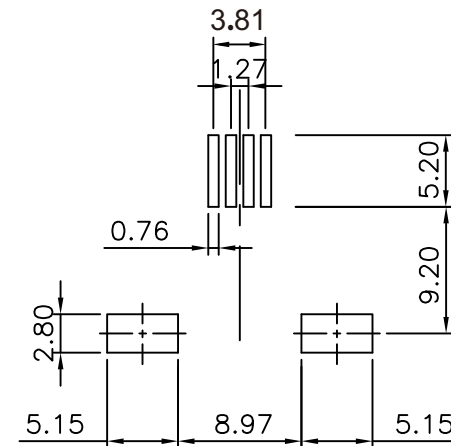

PCB LAYOUT
Ref.

RoHS Compliant

TOLERANCES ARE

MORETHANALL
PCB CONNECTORS
Cable ASSEMBLIES

煜倫股份有限公司

www.morethanall.com

DRAWING BY CY

CHECKED BY GENIUS

UNIT / mm

SCALE 1 : 1

DATE

SIZE A4

X, ±
.X ± 0.25
.XX ± 0.13
.XXX ± 0.05
ANG ±

P PROJECTION

照片框

ORDER INFORMATION

MJW11-KX06R-0604-LF

SERIES REEL LEADFREE
6P4C
06u" GOLD
NON EAR
BLACK

DESCRIPTION: RJ11, SMT TYPE SIDE ENTRY PCB JACK

MATERIALS:

- 1. CARRIER-PS (0.40mm THICK TAPE).
- 2. REEL-2mm THICK PLASTIC WHEEL.
- 3. COVER TAPE-PE (0.10mm THICK TAPE).

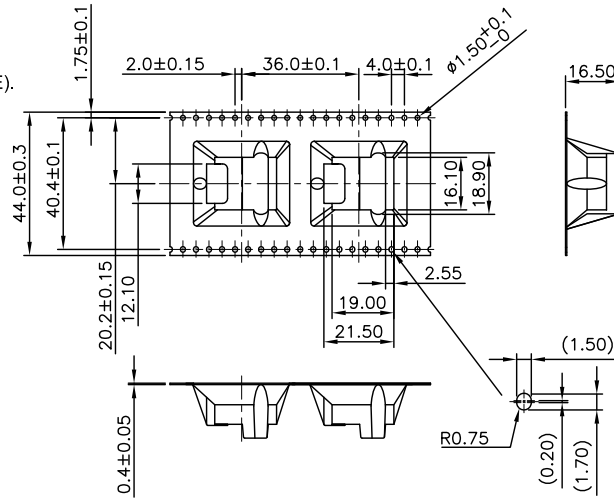

NOTES:

- 1. 10 EMPTY CAVITIES FOR BOTH OF TOP AND BOTTOM OF THE CARRIER.
- 2. 100 PCS PRODUCTS BE PACKAGED ON REEL.
- 3. 軸外保護帶 (繞二圈).

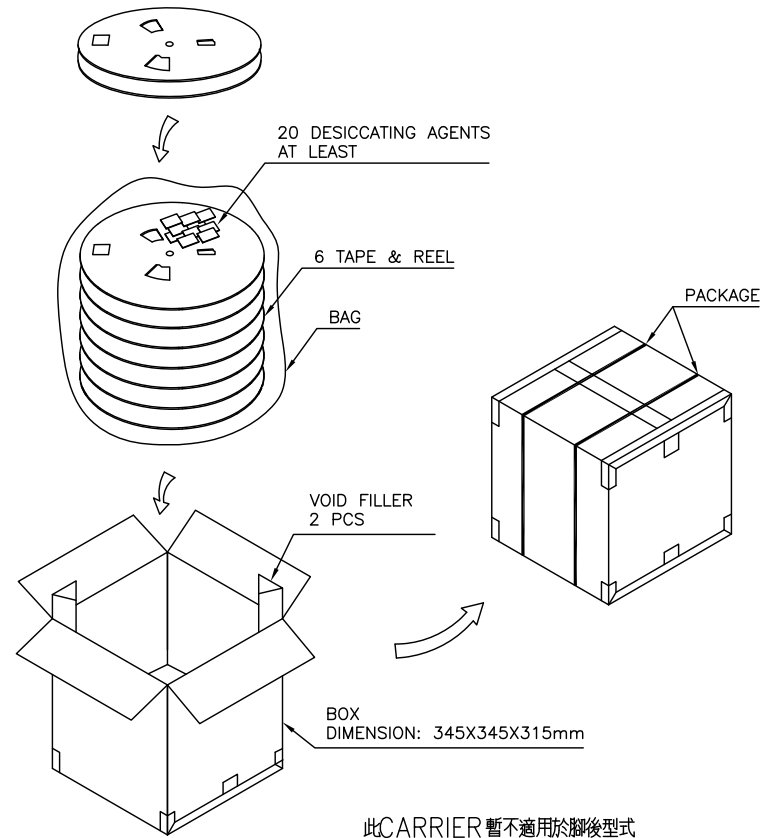
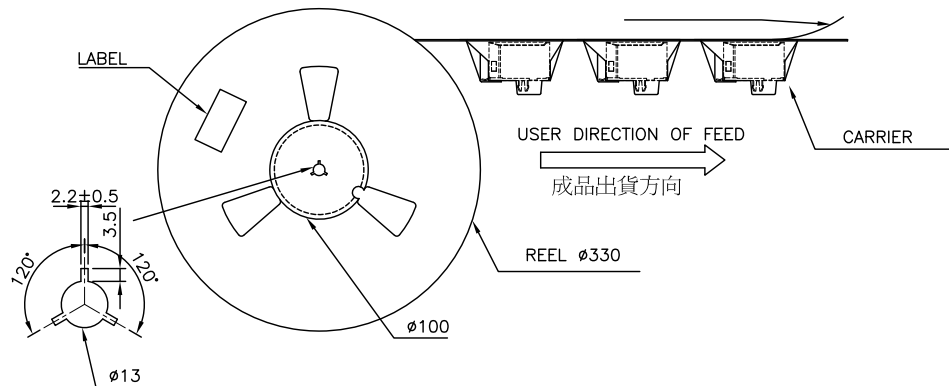
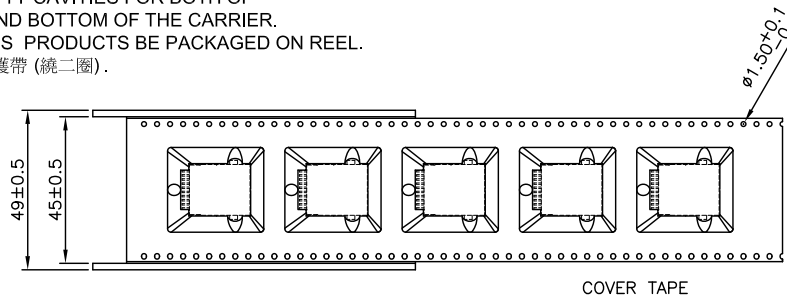

此CARRIER 暫不適用於腳後型式

-	-	600	6	100
G/W(Kg) Ref.	N/W(Kg) Ref.	QUANTITY (PCS)	REELS/ BOX	PCS/ REELS

RoHS Compliant

TOLERANCES ARE



煜倫股份有限公司

www.morethanall.com

DRAWING BY CY

CHECKED BY GENIUS

UNIT / mm

SCALE 1 : 1

DATE

SIZE A4

X, ±
.X ± 0.30
.XX ± 0.20
.XXX ± 0.10
ANG ±

PJECTION

照片框

ORDER INFORMATION

MJW11-KX06R-0604-LF

SERIES REEL LEADFREE
6P4C
REEL
06u" GOLD
NON EAR
BLACK

DESCRIPTION: TAPE & REEL PACKAGING SPEC.