

COPLANARITY:
THE MAXIMUM DISTANCE
BETWEEN LOWEST AND
HIGHEST PIN WHEN
HOUSING RESTS
ON A FLAT SURFACE

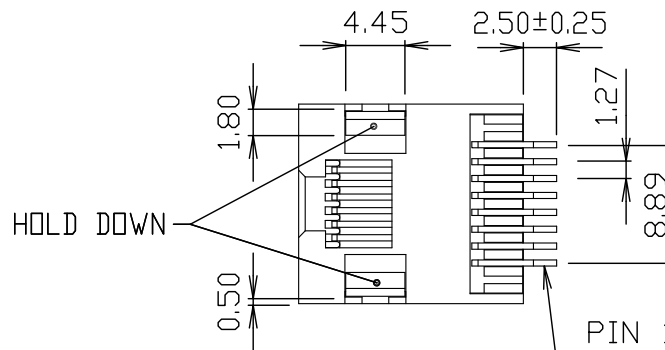

MATERIALS:

- HOUSING-PA9T GN2330
HEAT RESISTANT PLOYAMIDE RESIN
BLACK COLOR, UL94V-0
OR-DSM STANYL TE250F6 (NYLON-46)
HEAT DEFLECTION TEMP.290°
NONMETALLIC PEARL COLOR, UL94V-0
- CONTACTS-0.35mm THICK PHOS-BRONZE PLATED
WITH HARD GOLD AND GOLD FLASH
IN SOLDER AREA.
- HOLD DOWN-0.30mm THICK COPPER ALLOY,
PLATED WITH TIN.
CAVITY CONFIRMS TO FCC RULES AND REGULATIONS
PART 68,SUBPART F.

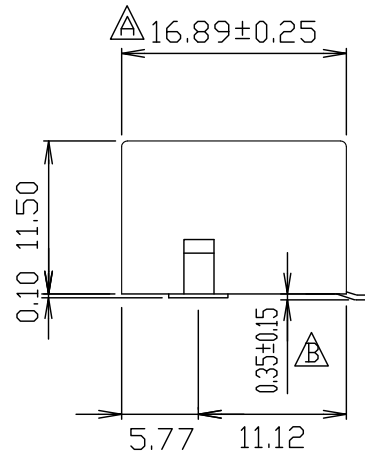
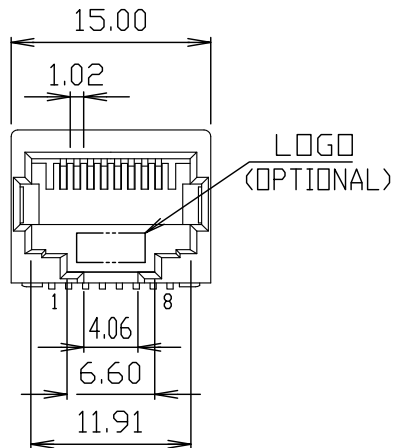
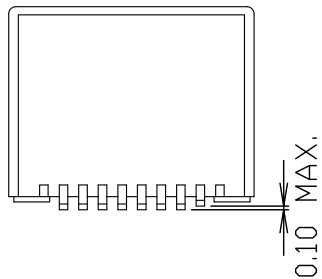
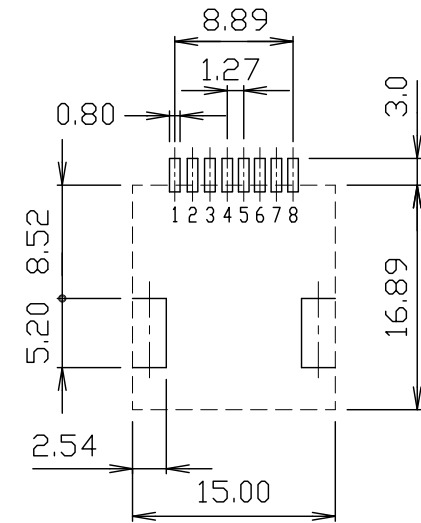

PCB LAYOUT
Ref.

RoHS Compliant

TOLERANCES ARE

MORETHANALL
PCB CONNECTORS
Cable ASSEMBLIES

煜倫股份有限公司

www.morethanall.com

DRAWING BY CY

CHECKED BY GENIUS

UNIT / mm SCALE 1 : 1

DATE

SIZE A4

X, ±
.X ± 0.25
.XX ± 0.13
.XXX ± 0.05
ANG ±

PJECTION

照片框

ORDER INFORMATION

MJW11-KX06N-1008-LF

SERIES | | | LEADFREE
| | | 10P8C
| | | INNER EAR
| | | 06u GOLD
| | | NON POST
| | | BLACK

DESCRIPTION: 10PDS. 8 CONTACTS, SOLDER TAB-INSIDE
LOW PROFILE 1 PORT, SIDE ENTRY SMT TYPE