

PCB LAYOUT
COMPONENT SIDE SHOWN

NOTES:

ELECTRICAL:

- 1. VOLTAGE RATING : 125 VAC.
- 2. CURRENT RATING : 1.5 AMP.
- 3. CONTACT RESISTANCE : 35 MILLIOHMS MAX.
- 4. INSULATION RESISTANCE : 1000 MEGOHMS MIN. @ 500 VDC.
- 5. DIELECTRIC STRENGTH : 1000 VAC 60Hz, 1MIN.

MECHANICAL:

- 1. HOUSING MATERIAL : HIGH TEMP. UL94V-0 BK.
- 2. CONTACT MATERIAL : PHOSPHOR BRONZE t=0.35mm.
- 3. PLATING : GOLD PLATING OVER NICKEL.
- 4. OPERATING LIFE : 750 CYCLES MIN.
- 5. PCB RETENTION POST-SOLDER: 10 LBS MIN.

ENVIRONMENTAL:

- 1. STORAGE : -40°C TO +85°C.
- 2. OPERATION: -40°C TO +85°C.
- 3. IR REFLOW SOLDERING TEMPERATURE: 255°C TO 265°C (5~10 SECONDS).

MATES WITH MODULAR PLUG CONFORMING TO
FCC PART 68, SUBPART F.

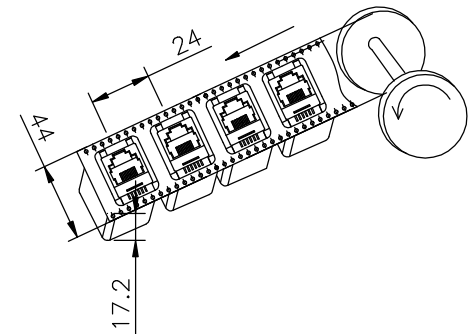

RoHS Compliant

TOLERANCES ARE

MORETHANALL
PCB CONNECTORS
Cable ASSEMBLIES

煜倫股份有限公司

www.morethanall.com

DRAWING BY CY

CHECKED BY GENIUS

UNIT / mm SCALE 1 : 1

DATE

SIZE A4

X, ±
.X ± 0.20
.XX ± 0.15
.XXX ± 0.10
ANG ± 5°

PJECTION

照片框

ORDER INFORMATION

MJVS12-KX06ER-0606-LF

SERIES REEL LEADFREE
BLACK EAR 6P6C
06 u" GOLD
NON EAR

DESCRIPTION: