

1. MECHANICAL DIMENSIONS :

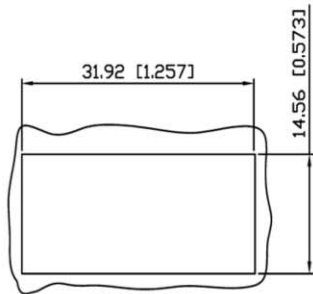
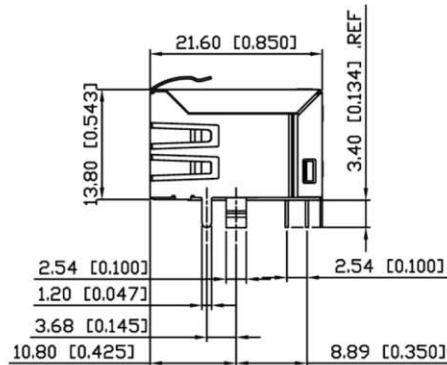
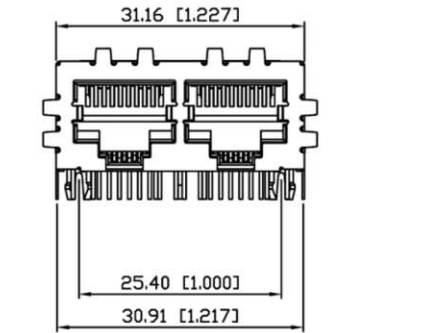

RECOMMENDED
PANEL CUTOUT DIMENSION

NOTES:

1. MATERIALS:
HOUSING-PBT POLYESTER UL94V-0
MIXED GLASS FIBER.
STANDARD COLOR-BLACK.
CONTACTS-0.35mm THICK PHOS-BRONZE PLATED
WITH 6u" GOLD IN CONTACT AREA, TIN IN
SOLDER AREA, AND UNDERPLATED NICKEL
IN ALL AREA.
SHIELD-0.25mm THICK COPPER ALLOY,
PLATED WITH NICKEL.
2. OPERATING TEMPERATURE : 0°C~70°C
3. CAVITY CONFORMS TO FCC RULES AND REGULATIONS
PART 68,SUBPART F.
4. UNSPECIFIED TOLERANCE: .XX ±0.25[0.010]
.X ±0.30[0.012]

RECOMMENED PLUG DIMENSION:

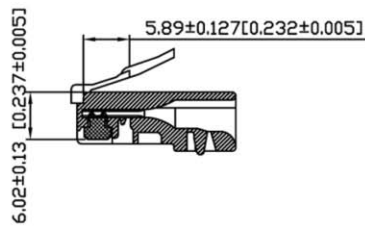

2. PCB LAYOUT :

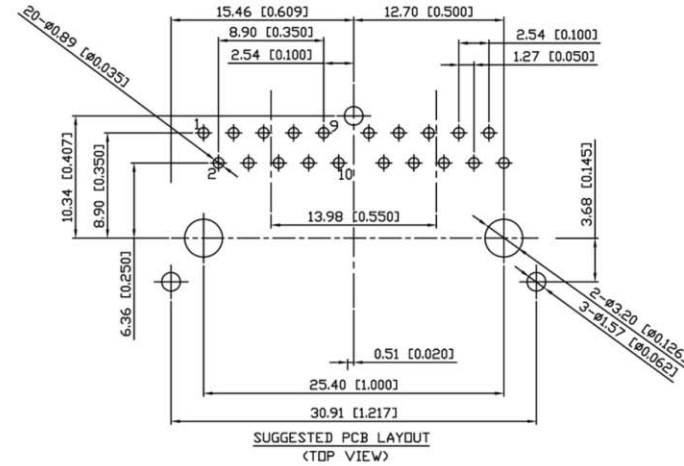

RoHS Compliant

TOLERANCES ARE

MORETHANALL
PCB CONNECTORS
Cable ASSEMBLIES

DRAWING BY CY
CHECKED BY GENIUS
UNIT / mm SCALE 1 : 1
DATE

X, ±
.X ± 0.25
.XX ± 0.15
.XXX ± 0.05
ANG ±

照片框

ORDER INFORMATION

MJF13T110A2-KF06A36-0808-LF

SERIES

LEADFREE

8P8C

FRONT TAB 3.68mm

06u" GOLD

FULL SPRING

BLACK

煜倫股份有限公司

www.morethanall.com

SIZE A4

PJECTION

DESCRIPTION:

3. SCHEMATIC:

LAN CHIP SIDE

RJ45 CABLE SIDE

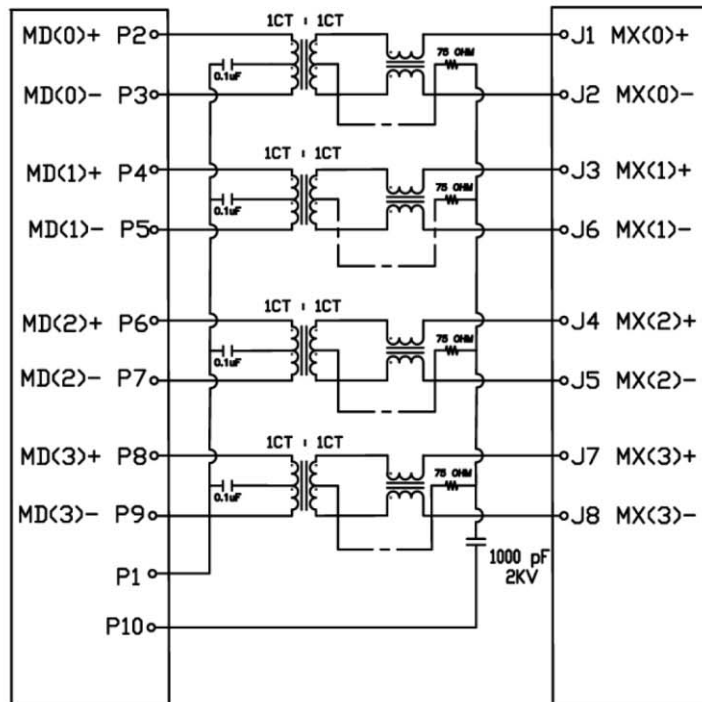

4. ELECTRICAL CHARACTERISTICS :

TEST NOTES:(25°±5°C)

- TR:(100KHz,0.1V); 100%
PINS:(P2,P3):(J1,J2)=1:1±3%;(P4,P5):(J3,J6)=1:1±3%
PINS:(P6,P7):(J4,J5)=1:1±3%;(P8,P9):(J7,J8)=1:1±3%
- LX:(100KHz,100mV,8mA, DC Bias) 100%
PINS:(P2,P3),(P4,P5),(P6,P7),(P8,P9)=350uH MINIMUM
- DCR: 100%
PINS:(J1,J2),(J3,J6),(J4,J5),(J7,J8)=1.0 MAXIMUM
- INSERTION LOSS:
-0.8dB MAXIMUM AT 0.3MHz TO 100MHz;
-1.2dB MAXIMUM AT 100MHz TO 120MHz
- RETURN LOSS:
-18dB MINIMUM AT 0.5MHz TO 40MHz;
-12+20Log(f/80MHz)dB MINIMUM AT 40MHz TO 100MHz
- CROSS TALK:
-33+20Log(f/100MHz)dB MINIMUM AT 0.1MHz TO 100MHz
- COMMON TO DIFFERENTIAL MODE REJECTION:
-35dB MINIMUM AT 300KHz TO 100MHz
- COMMON TO COMMON MODE REJECTION:
-30dB MINIMUM AT 300KHz TO 100MHz

RoHS Compliant

TOLERANCES ARE

MORETHANALL
PCB CONNECTORS
Cable ASSEMBLIES

DRAWING BY CY

CHECKED BY GENIUS

UNIT / mm SCALE 1 : 1

DATE

SIZE A4

X, ±
.X ± 0.25
.XX ± 0.15
.XXX ± 0.05
ANG ±

PJECTION

照片框

ORDER INFORMATION

MJF13T110A2-KF06A36-0808-LF

SERIES

LEADFREE
8P8C
FRONT TAB 3.68mm
06u" GOLD
FULL SPRING
BLACK

煜倫股份有限公司

www.morethanall.com

DESCRIPTION: