

PC Board Layout

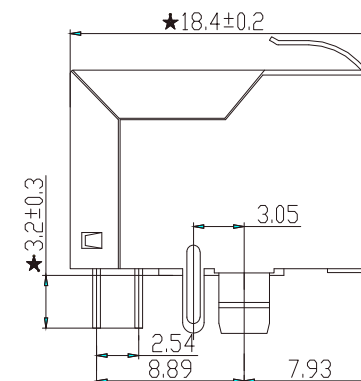
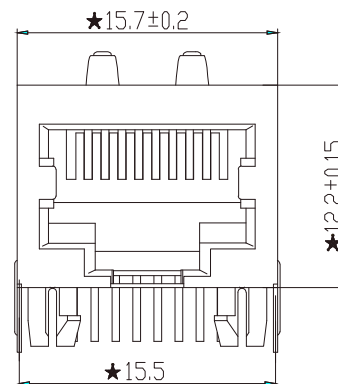
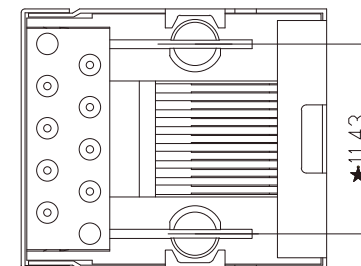

NOTES:

ELECTRICAL:

1. VOLTAGE RATING: 125 VAC RMS.
2. CURRENT RATING: 1.5 AMP.
3. CONTACT RESISTANCE: 30 MILLIOHMS MAX.
4. INSULATION RESISTANCE: 500 MEGOHMS MIN @ 500 VDC.
5. DIELECTRIC STRENGTH: 1000 VAC RMS 50Hz or 60Hz, 1MIN.

MECHANICAL:

1. HOUSING & INSERT MATERIAL: PBT UL94V-0.
2. CONTACT MATERIAL: DIAMETER 0.45MM PHOSPHOR BRONZE GOLD PLATING OVER NICKEL.
3. SHIELD: 0.20 ~ 0.25MM THICKNESS BRASS WITH NICKEL PLATED.
4. MATING/UNMATING FORCE: 2.2KG.F MAX.
5. RETENTION STRENGTH: 7.7KG.F MIN BETWEEN JACK AND PLUG.
6. OPERATING LIFE: 750 CYCLES MIN.

ENVIRONMENTAL:

1. STORAGE: -40°C ~ +85°C RELATIVE HUMIDITY<70%.
2. OPERATION: -40°C ~ +85°C.

The mark with ★ is the key inspection dimension for QC

RoHS Compliant

TOLERANCES ARE



煜倫股份有限公司

www.morethanall.com

DRAWING BY CY

CHECKED BY GENIUS

UNIT / mm

SCALE 1 : 1

DATE

SIZE A4

X, ±
.X ± 0.25
.XX ± 0.15
.XXX ± 0.05
ANG ±

PJECTION

照片框

ORDER INFORMATION

MJF12-KT06B3-0808-LF

SERIES | LEADFREE
8P8C
REAR TAB 3.05mm
06u" GOLD
TOP SPRING
BLACK

DESCRIPTION: