

TECHNICAL CHARACTERISTICS

1. General Characteristics

Dimension: 16.96L x 13.85W x 1.50H mm
 Weight: Approx. 0.48 g
 Contact principle: Friction technology
 Operating position: Shaft up / Down / Horizontal
 Mounting System: SMT Type (without post)
 Function: Hinge Type
 Durability: 5,000 cycles min. (Terminal)
 500 cycles min. (Locking system)

2. Mechanical Characteristics

Insulation material: Thermoplastic, UL 94V-0
 RoHS Directive 2011/65/EU Compliant

3. Electrical Characteristics

Number of contacts: 6 pins
 Contact resistance: 100 mΩ max.
 Insulation resistance: >1000 M Ω / 500 VDC

4. Solderability

Wave: Not applicable
 IR reflow: 260 °C, 10 sec. Max.
 Manual soldering: 360 °C, 3 sec. Max.

5. Environmental Characteristics

Operating temperature: - 30 °C ~ + 85°C
 Operating humidity: 10 % ~ 95 % RH
 Storage temperature: - 30 °C ~ + 85°C
 Storage humidity: 10 % ~ 95 % RH

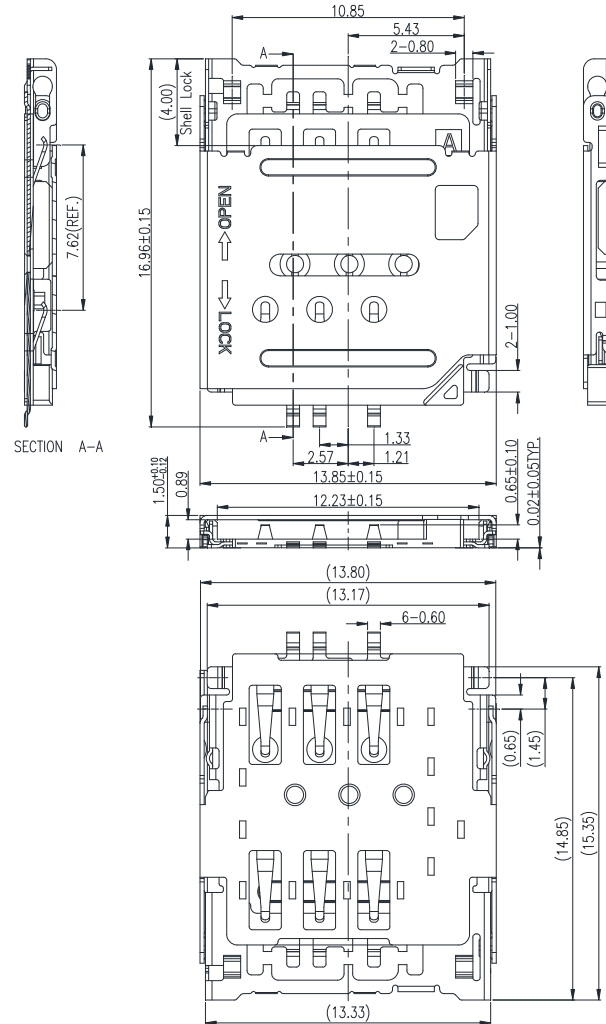

Unit: mm; Tolerances: ±0.20 mm
Mechanical outline dimension

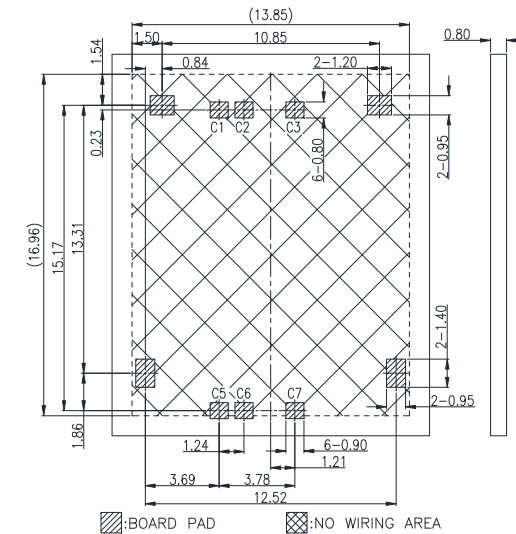
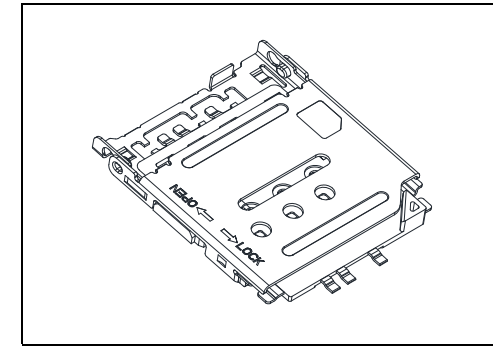

Unit: mm; Tolerances: ±0.05 mm
Reference dimension for PCB layout

Note:

1. Coplanarity of solder pins 0.08mm max. (Before reflow).
2. Recommended thickness of solder paste > 0.15mm.

RoHS Compliant

TOLERANCES ARE

MORETHANALL
 PCB CONNECTORS
 Cable ASSEMBLIES

DRAWING BY CY

X, ±

CHECKED BY GENIUS

.X ±

UNIT / mm

SCALE 1 : 1

.XXX ±

DATE

ANG ±

SIZE A4

PJECTION

照片框

ORDER INFORMATION

MISCV-W1415XR-06-LF

SERIES | | | | | LEADFREE

90°SMT | | | | | REEL

NON POST

HIGH 1.50mm

PAD TO PAD 14.85mm

煜倫股份有限公司

www.morethanall.com

DESCRIPTION:

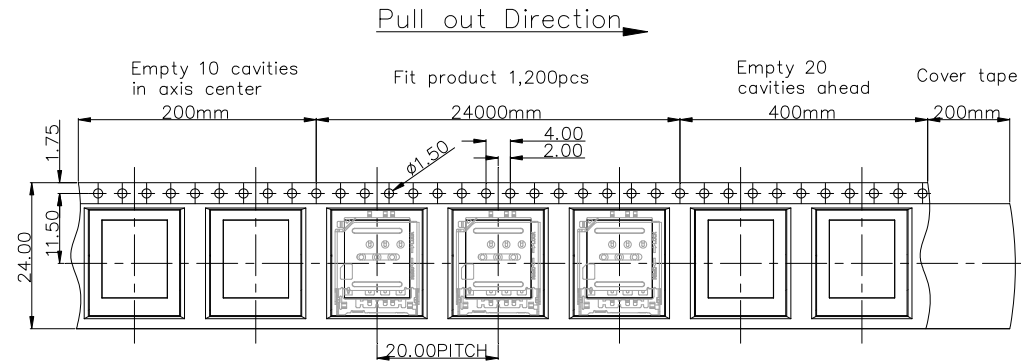
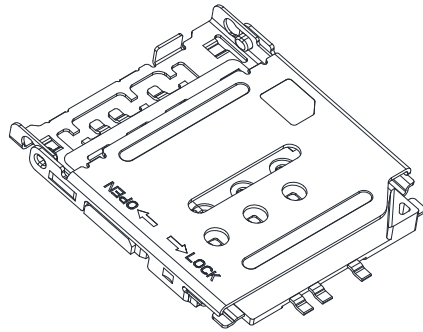

PACKING INFORMATIONS:

Carrier Tape (Meet Standard EIA-481)

Q'ty: 1,200 pcs per reel
 Meas.: dia. 330 mm, W 24mm
 N.W.: 0.58 KG
 G.W.: 1.18 KG

Q'ty: 12,000 pcs per carton
 (10 reels set in order)
 Meas.: 365L x 365W x 360H mm
 N.W.: 5.8 KG
 G.W.: 12.8 KG

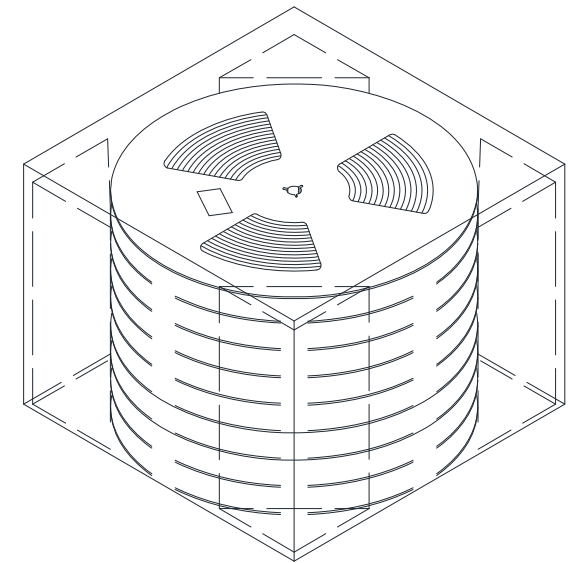
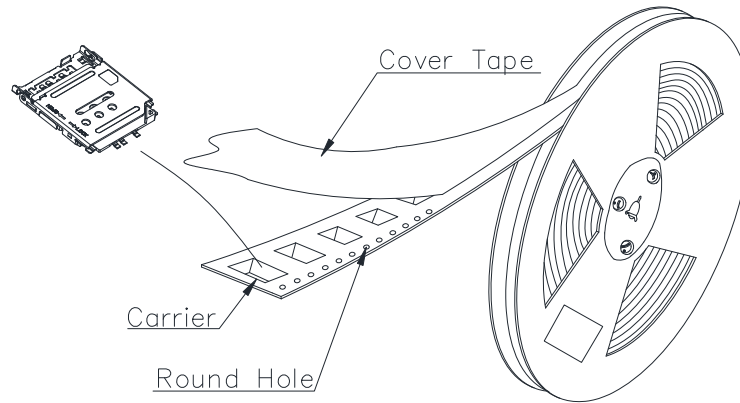

RoHS Compliant

TOLERANCES ARE

MORETHANALL
 PCB CONNECTORS
 Cable ASSEMBLIES

DRAWING BY CY

X. ±

CHECKED BY GENIUS

.X ±

UNIT / mm

SCALE 1 : 1

.XXX ±

DATE

ANG ±

SIZE A4

PJECTION

照片框

ORDER INFORMATION

MISCV-W1415XR-06-LF

SERIES | | | | | LEADFREE
 | | | | | 06WAY
 | | | | | REEL
 | | | | | NON POST
 | | | | | HIGH 1.50mm
 | | | | | PAD TO PAD 14.85mm

90°SMT

DESCRIPTION:

煜倫股份有限公司

www.morethanall.com