

SECTION A-A  
SCALE 4:1

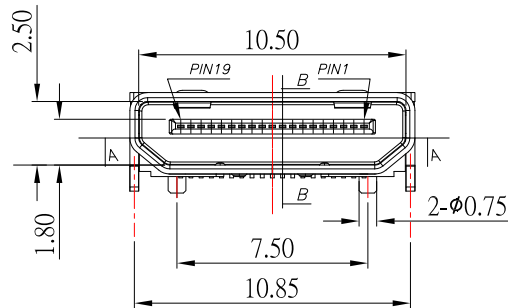

SECTION B-B  
SCALE 4:1

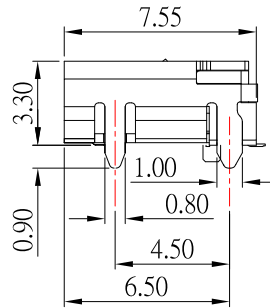

DETAIL A  
SCALE 16:1

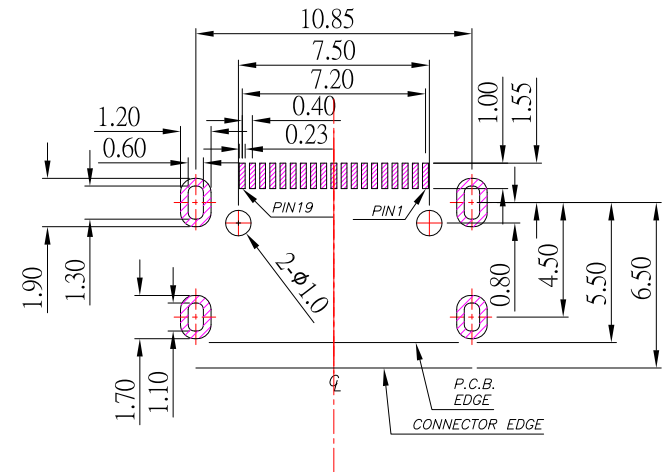
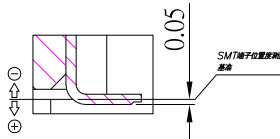
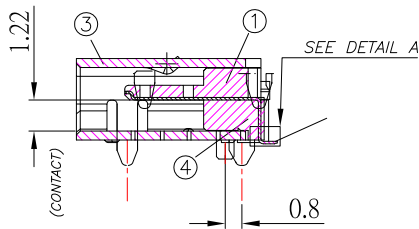

RECOMMENDED PCB LAYOUT(TOP VIEW)

NOTE:

1.MATERIAL:

- 1.1 HOUSING: LCP,UL94V-0 , BLACK
- 1.2 CONTACT: PHOSPHOR BRONZE
- 1.3 SHEEL: BRASS

2.PLATING :

- 2.1 CONTACT: PLATED GOLD IN MATING AREA ;  
TIN PLATED ON SOLDER BALLS ;  
NICKEL UNDER PLATED OVERALL
- 2.2 SHELL: NICKEL UNDER PLATED SURFACE LAYER  
OR GOLD UNDER PLATED SURFACE LAYER

3.MECHANICAL:

- 3.1 INSERTION FORCE: 4.5 Kgf MAX
- 3.2 WITHDRAWAL FORCE: 0.71~2.55 Kgf

RoHS Compliant

TOLERANCES ARE

**MORETHANALL**  
PCB CONNECTORS  
Cable ASSEMBLIES

煜倫股份有限公司

www.morethanall.com

DRAWING BY CY

CHECKED BY GENIUS

UNIT / mm

SCALE 1 : 1

DATE

SIZE A4

PJECTION

Up to 5 ±0.2  
Above 5 ~ 15 ±0.3  
Above 15 ~ 30 ±0.4  
Above 30 ~ 50 ±0.5  
Angle ±0.3°

照片框

ORDER INFORMATION

MHDMI-SWP-19-LF

SERIES LEADFREE  
19WAY  
POST  
90°SMT  
FEMALE

DESCRIPTION: