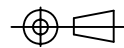

NOTES :
 1. MATERIAL : HIGH TEMPERATURE
 INSULATOR : THERMOPLASTIC , UL94V-0.
 COLOR : BLACK
 CONTACT : PHOSPHOR BRONZE.

MHC-W33-401-LF
 LEADFREE

RoHS Compliant

A			PART NO. MHC-W33-401		TOLERANCES ARE .X ± 0.2 .XX ± 0.1 .XXX ± AWG	DESCRIP TION:			
			DWG NO. MHC-W33-401						
B	焯倫股份有限公司		FILE NO.		DRAWING BY	AREA	REVISIONS	HK	DATE
			UNIT / mm	SCALE 1:1	PROJECTION 				

1 2 3 4 5 6 7 8 9 0

J
I
H
G
F
E
D
C
B
A

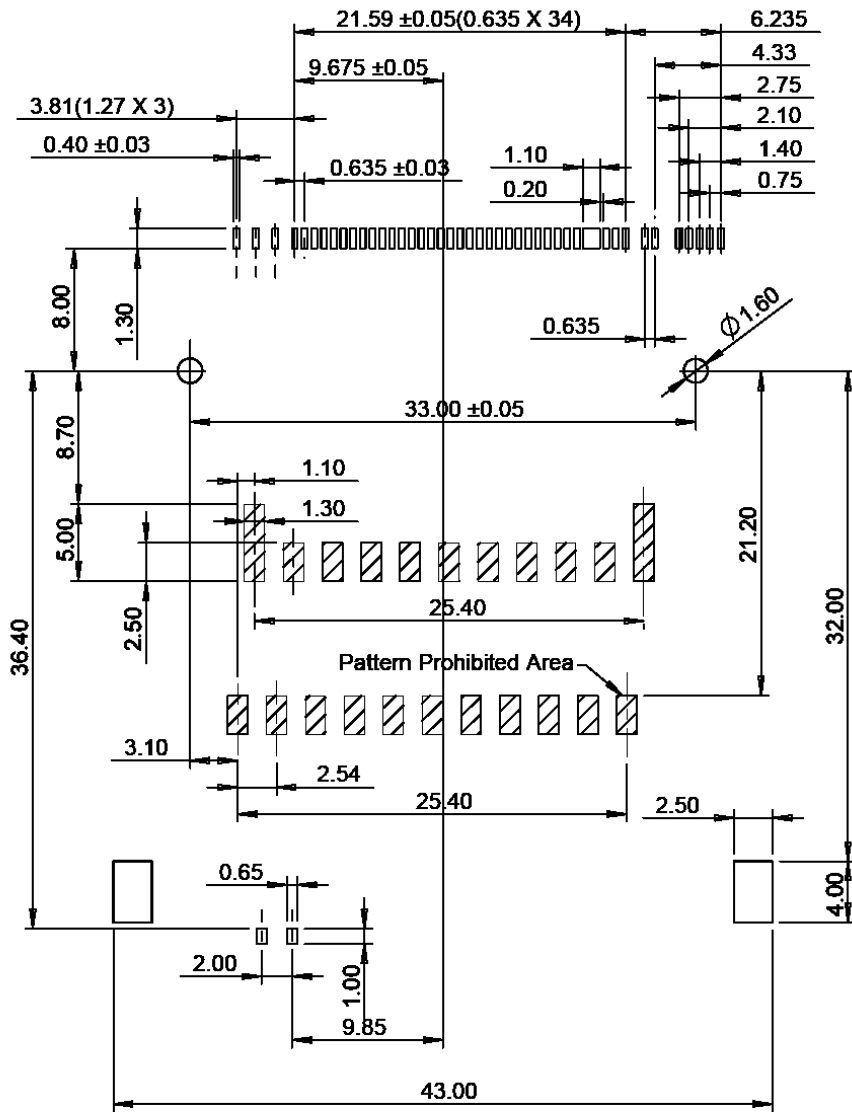

RECOMMEND PCB LAYOUT

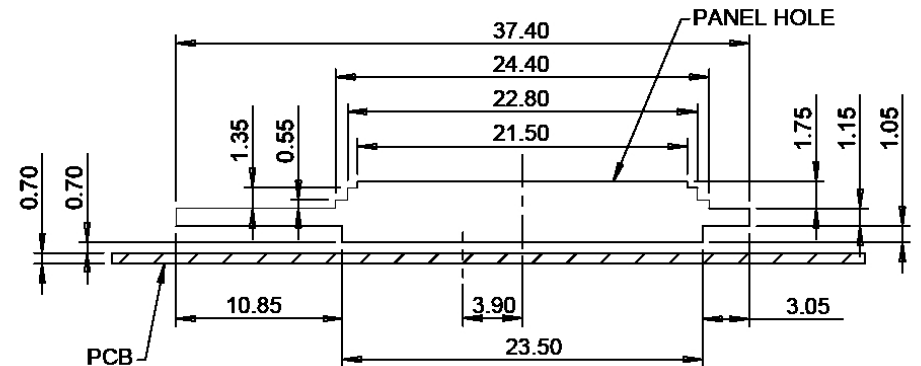

RECOMMEND PANEL HOLE



PART NO. MHC-W33-401

DWG NO. MHC-W33-401

CHECKED BY CY

TOLERANCES ARE

DESCRIP TION:

FILE NO.

DRAWING BY

.X ± 0.2

AREA

UNIT / mm

SCALE 1:1

PROJECTION

.XX ± 0.1

REVISIONS

HK

DATE

煜倫股份有限公司

.XXX ± AWG

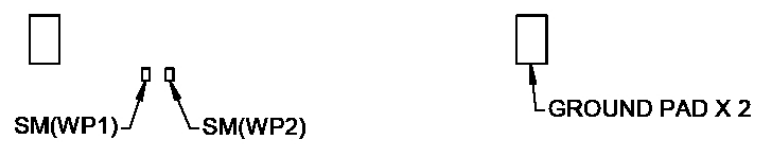
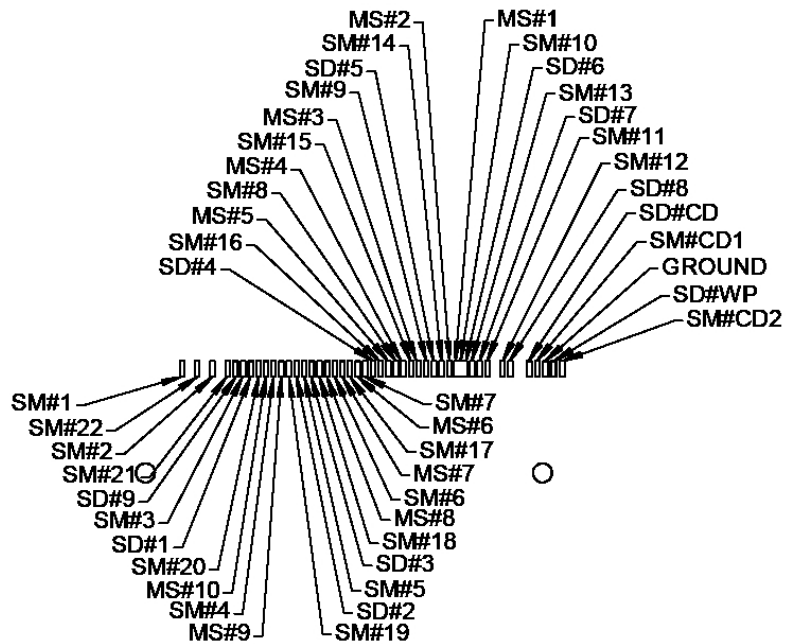

PIN ASSIGNMENT

PIN DEFINITION

PIN NO.	MEMORY CARD PIN NO.	PIN NO.	MEMORY CARD PIN NO.	PIN NO.	MEMORY CARD PIN NO.
SM#1	SM-1 (GND)	SM#16	SM-16 (I/O8)	SM(WP1)	SM (WP1)
SM#22	SM-22 (VCC)	MS#5	MS-5(RESERVED1)	SM(WP2)	SM (WP2)
SM#2	SM-2 (CLE)	SM#8	SM-8 (I/O3)		
SM#21	SM-21 (CE)	MS#4	MS-4 (SDIO)		
SD#9	SD-9 (DAT2)	SM#15	SM-15 (I/O7)		
SM#3	SM-3 (ALE)	MS#3	MS-3 (VCC)		
SD#1	SD-1 (DAT3)	SM#9	SM-9 (I/O4)		
SM#20	SM-20 (RE)	SD#5	SD-5 (CLK)		
MS#10	MS-10 (GND)	SM#14	SM-14 (I/O6)		
SM#4	SM-4 (WE)	MS#2	MS-2 (BS)		
MS#9	MS-9 (VCC)	MS#1	MS-1 (GND)		
SM#19	SM-19 (R/B)	SM#10	SM-10 (GND)		
SD#2	SD-2 (CMD)	SD#6	SD-6 (GND)		
SM#5	SM-5 (WP)	SM#13	SM-13 (I/O5)		
SD#3	SD-3 (GND)	SD#7	SD-7 (DAT0)		
SM#18	SM-18 (GND)	SM#11	SM-11 (GND)		
MS#8	MS-8 (SCLK)	SM#12	SM-12 (VCC)		
SM#6	SM-6 (I/O1)	SD#8	SD-8 (DAT1)		
MS#7	MS-7(RESERVED2)	SD#CD	SD (CD)		
SM#17	SM-17 (LVD)	SM#CD1	SM (GND)		
MS#6	MS-6 (INS)	GND	SD (GND)		
SM#7	SM-7 (I/O2)	SD#WP	SD (WP)		
SD#4	SD-4 (VCC)	SM#CD2	SM (CD2)		



PART NO. MHC-W33-401

DWG NO. MHC-W33-401

CHECKED BY CY

TOLERANCES ARE

DESCRIP TION:

煜倫股份有限公司

FILE NO.

DRAWING BY

.X ± 0.2

.XX ± 0.1

.XXX ±

AWG

AREA

REVISIONS

HK

DATE

UNIT / mm

SCALE 1:1

PROJECTION

SD CIRCUIT :

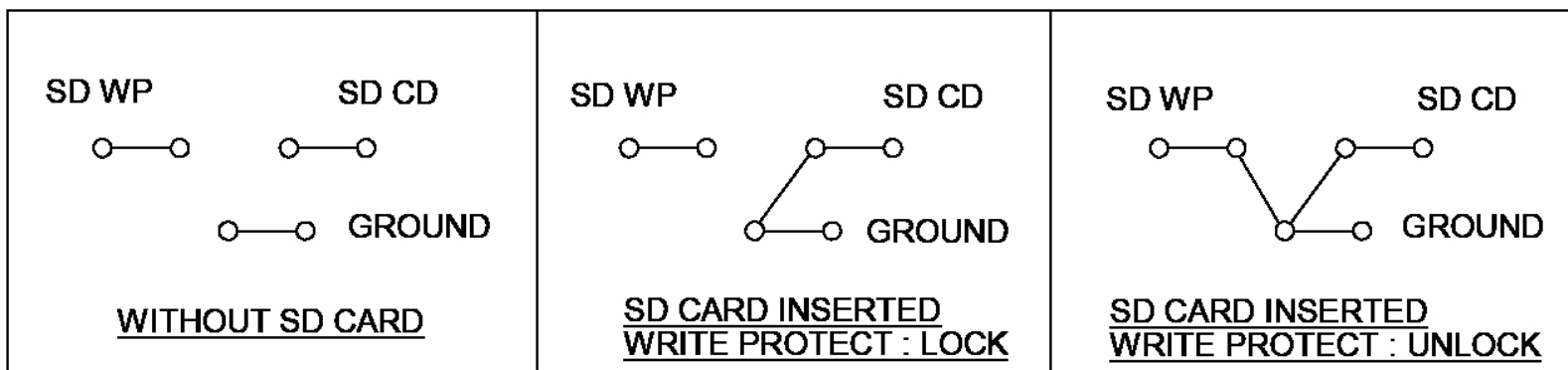

SMC CIRCUIT :

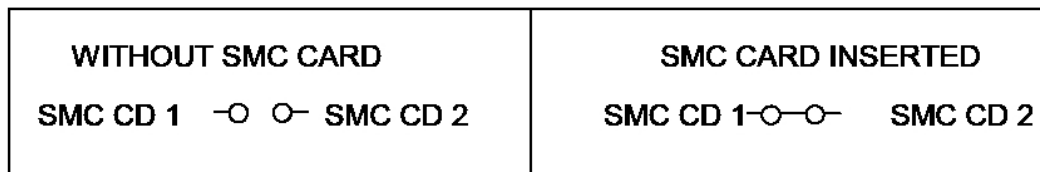

PART NO. MHC-W33-401

DWG NO. MHC-W33-401

CHECKED BY CY

TOLERANCES ARE

DESCRIP TION:

4IN1 CARD CONNECTOR

FILE NO.

DRAWING BY

.X ± 0.2
.XX ± 0.1
.XXX ±
AWG

AREA

REVISIONS

HK

DATE

煜倫股份有限公司

UNIT / mm

SCALE 1:1

PROJECTION

