

A	COLOR	B
1	RED	1
4	BLACK	2

NOTES:

1. ALL DIMENSIONS ARE "mm".
2. THE PRODUCT MUST BE COMPLY WITH THE DIRECTIVE OF ROHS.

ELECTRICAL TESTING:

1. 100% OPEN/SHORT TEST
2. CONTACT RESISTANCE: 5Ω Max
3. INSULATION RESISTANCE: 20MΩ Min

NO.	ITEM.	DESCRIPTION	Q'TY
1	WIRE:	UL1015 #16 BLACK	1PCS
2	WIRE:	UL1015 #16 RED	1PCS
3	HOUSING:	MF-SH-2X02	1PCS
4	TERMINAL:	MF-FT-16	2PCS
5	TERMINAL BLOCK:	TBH050-SW-02	1PCS
6	Waterproof label:		2PCS

RoHS Compliant

TOLERANCES ARE

**MORETHANALL**  
PCB CONNECTORS  
Cable ASSEMBLIES

煜倫股份有限公司

www.morethanall.com

DRAWING BY CY

CHECKED BY GENIUS

UNIT / mm SCALE 1 : 1

DATE

SIZE A4

X. ±  
.X ±  
.XX ±  
.XXX ±  
ANG ±

PJECTION

照片框

ORDER INFORMATION

MFTBH-B020216TW1-F24N-LF

SERIES

LEADFREE  
610mm  
FEMALE TO FEMALE  
TWISTED WIRE  
16 AWG  
04 TO 04 WAY

DESCRIPTION: CABLE ASS'Y

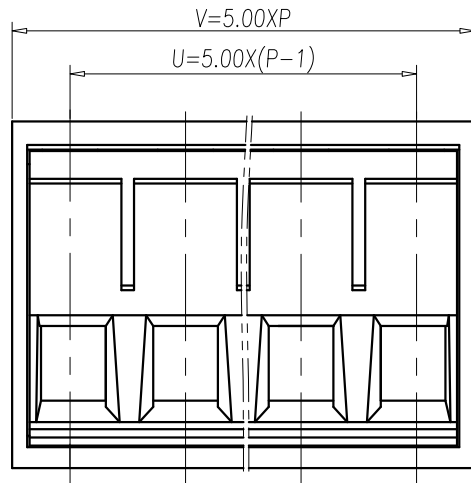
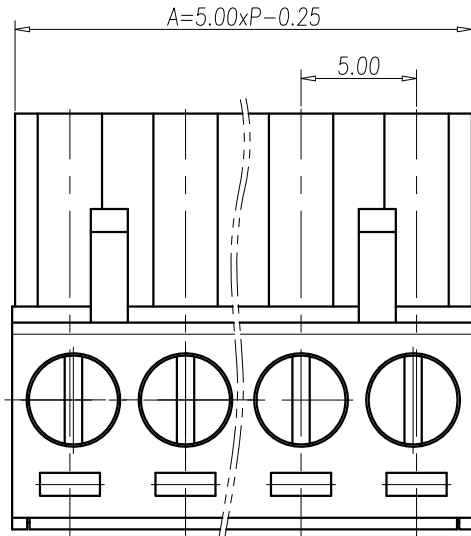

P	2	3	4	5	6	7	8	9
U	5.00	10.00	15.00	20.00	25.00	30.00	35.00	40.00
V	10.00	15.00	20.00	25.00	30.00	35.00	40.00	45.00
P	10	11	12	13	14	15	16	17
U	45.00	50.00	55.00	60.00	65.00	70.00	75.00	80.00
V	50.00	55.00	60.00	65.00	70.00	75.00	80.00	85.00
P	18	19	20	21	22	23	24	
U	85.00	90.00	95.00	100.00	105.00	110.00	115.00	
V	90.00	95.00	100.00	105.00	110.00	115.00	120.00	

Total Pitch Tolerances		Normal Dimension Tolerances	
0~30	±0.20	0~30	±0.25
over 30~53	±0.25	over 30~53	±0.30
over 53~70	±0.30	over 53~70	±0.35
over 70~90	±0.35	over 70~90	±0.44
over 90~115	±0.44	over 90~115	±0.55
over 115~150	±0.55	over 115~150	±0.70
over 150~200	±0.70	over 150~200	±0.85
over 200~250	±0.85	over 200~250	±1.00
over 250~320	±1.00	over 250~320	±1.20

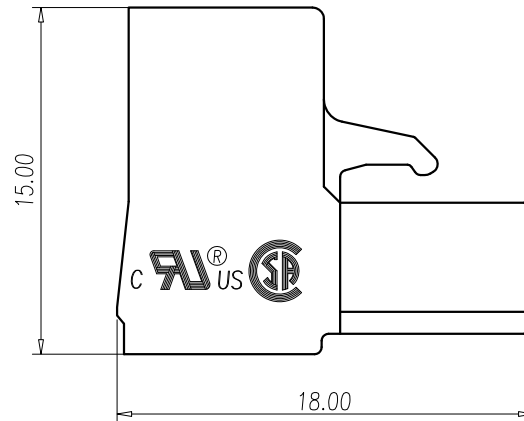

NOTES 1:

UL Standard :

1. Rating: 300V 15A
2. Insulation Withstands Voltage: AC 2000V at 1 minute
3. Using Temperature Range: -40°C~+115°C
4. Screw Torque Value: 0.5N·m
5. Suitable Electric Wire: AWG 28~12(sol)  
30~12(str)

IEC Standard:

1. Rating: 600V 18A
2. Rate Impulse Voltage: 4000V
3. Insulation Resistance: 500MΩ or more at DC500V
4. Material Group : I
5. Pollution Degree : 2
6. Overvoltage Category: II
7. Using Temperature Range: -40°C~+110°C
8. Screw Torque Value: 0.4N·m
9. Suitable Electric Wire: 0.2~2.5mm²

NOTES 2:

1. RoHS compliance
2. Strip Length: 7~8mm

ITEM	NAME OF PART	MATERIAL	NOTES
5	SCREW	STEEL	M2.5/Zn Plated
4	WIRE CAGE	STEEL	Zn Plated
3	CLAMP	COPPER ALLOY	Tin Plated
2	COVER	PA66	UL94-V0 GREEN
1	HOUSING	PA66	UL94-V0 GREEN

RoHS Compliant

TOLERANCES ARE

**MORETHANALL**  
PCB CONNECTORS  
Cable ASSEMBLIES

DRAWING BY CY

CHECKED BY GENIUS

UNIT / mm

SCALE 1:1

DATE

SIZE A4

PPOJECTION

X, ±  
.X ±  
.XX ±  
.XXX ±  
ANG ±

照片框

ORDER INFORMATION

TBH050-SW-xx-LF

SERIES

LEADFREE

02~24WAY

SCREW 90°

FEMALE

煜倫股份有限公司

www.morethanall.com

DESCRIPTION: