

NOTE :
 * Material : Nylon UL 94V-0 or UL 94V-2
 * Standard color : White
 * Finish : Plated Tin over Nickel
 * Electrical rating : TUV 250V 7A , AC/DC
 * 4-24 circuits available

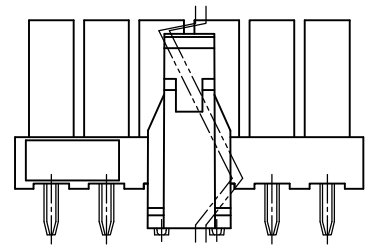

MFB-SDL-2Xxx-LF
 LEADFREE
 RoHS Compliant

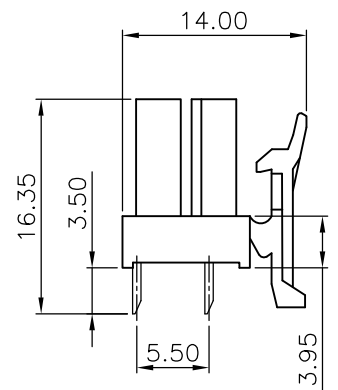
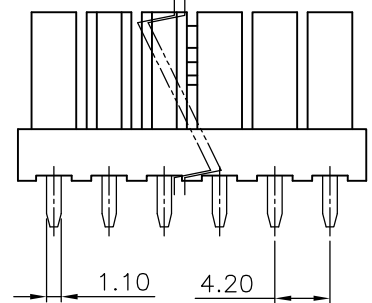
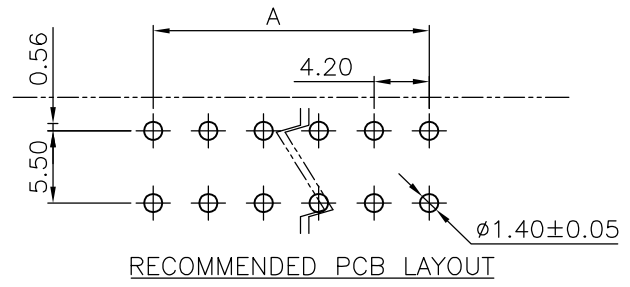
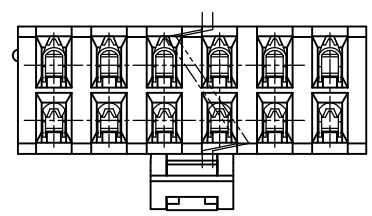

Circuits	Part No.	Dim. A	Dim. B	Circuits	Part No.	Dim. A	Dim. B
2	MFB-SDL-2X01	---	5.5	22	MFB-SDL-2X11	42.00	47.5
4	MFB-SDL-2X02	4.20	9.7	24	MFB-SDL-2X12	46.20	51.7
6	MFB-SDL-2X03	8.40	13.9	26	MFB-SDL-2X13	50.40	55.9
8	MFB-SDL-2X04	12.60	18.1	28	MFB-SDL-2X14	54.60	60.1
10	MFB-SDL-2X05	16.80	22.3	30	MFB-SDL-2X15	58.80	64.3
12	MFB-SDL-2X06	21.00	26.5	32	MFB-SDL-2X16	63.00	68.5
14	MFB-SDL-2X07	25.20	30.7	34	MFB-SDL-2X17	67.20	72.7
16	MFB-SDL-2X08	29.40	34.9	36	MFB-SDL-2X18	71.40	76.9
18	MFB-SDL-2X09	33.60	39.1	38	MFB-SDL-2X19	75.60	81.1
20	MFB-SDL-2X10	37.80	43.3	40	MFB-SDL-2X20	79.80	85.3

MORETHANALL
 CONNECTORS
 ASSEMBLIES

PART NO. MFB-SDL-2Xxx

DWG NO. MFB-SDL-2Xxx

FILE NO.

UNIT / mm

SCALE 1:1

CHECKED BY CY

DRAWING BY

PROJECTION

TOLERANCES ARE

.X ± 0.2
 .XX ±
 .XXX ±
 AWG

DESCRIP TION:

AREA	REVISIONS	HK	DATE

煜倫股份有限公司