

Specifications:  
 Current Rating: 4A(2~5P); 2A(6~8P); 1.5A(9~12P) AC/DC  
 Voltage Rating: 250V(2~4P); 60V(5P); 30V(6~12P) AC/DC  
 Contact Resistance: 5m ohm. Max.  
 Insulation Resistance: 100M ohm. Min.  
 Withstanding Voltage: 500V AC/Minute  
 Operating Temperature Range: -40°C ~ +100°C  
 Waterproof Rate: IP67  
 Material and Finish  
 See Table

Pin Assignments Front View

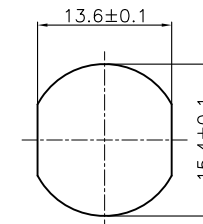
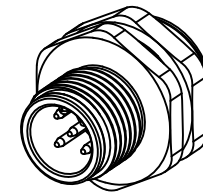
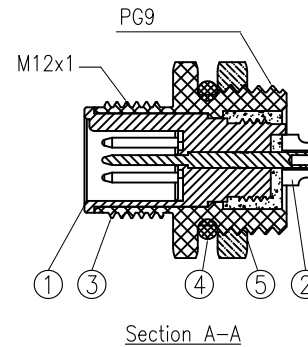
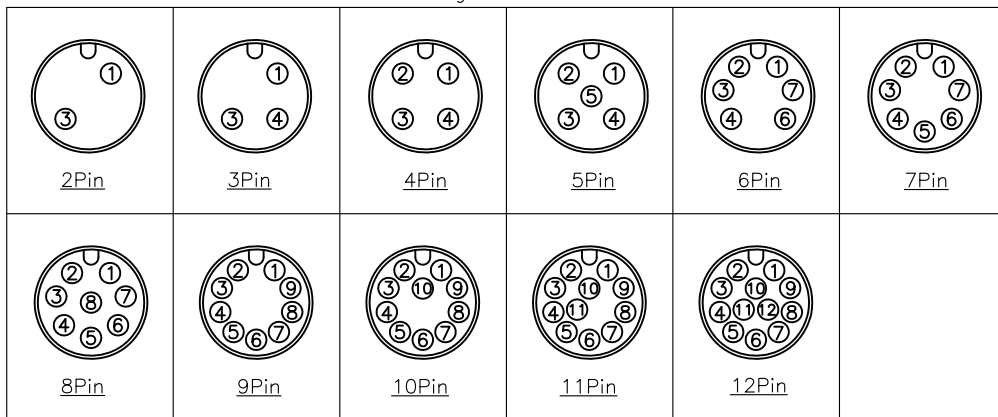

PG9 Recommended  
 Panel CUT-Out  
 Thickness 4.0 Max.

ITEM	Description	Material	Remark	Q'TY
1	Insulator	Nylon 66	UL94V-0 Black	1
2	Terminal	Copper Alloy	Gold Plated 1u"	2~12
3	Shell	Zinc Alloy	Nickel Plated 60u"	1
4	Seal ring	Silicone	Red	1
5	Nut	Copper Alloy	PG9 or M16 Nickel Plated 60u"	1

RoHS Compliant

TOLERANCES ARE

**MORETHANALL**  
 PCB CONNECTORS  
 Cable ASSEMBLIES

煜倫股份有限公司

www.morethanall.com

DRAWING BY CY

CHECKED BY GENIUS

UNIT / mm SCALE 1 : 1

DATE

SIZE A4

X, ±  
 .X ± 0.30  
 .XX ± 0.20  
 .XXX ±  
 ANG ±

P PROJECTION

照片框

ORDER INFORMATION

M12-PSPANO-xx-LF  
 SERIES | | | | LEADFREE  
 | | | | 02~12WAY  
 | | | | RING  
 MALE | | | | NUT  
 | | | | PANEL FRONT  
 | | | | SOLDER

DESCRIPTION: M12 A CODE PLUG REAR FASTENED SOLDER TYPE