

SPECIFICATION

MATERIAL

Insulator: PBT&glass fiber reinforced UL94V-0

Contacts: Phosphor Bronze

Latch Shell: Zinc alloy

Metal Shell: Steel

CONTACT PLATING

S=1u" gold on mating length, 100u" tin on solder tails
base nickel=40u"

SHELL PLATING

100u" nickel over 40u" copper

ELECTRICAL

Current rating: 1 Amps max.

Contact resistance: 30 mohms max.

Insulation resistance: 3000 Mohms min @ 500 VDC

Dielectric withstanding voltage: 500 VAC / minute

Operating temperature: -55°C TO +105°C

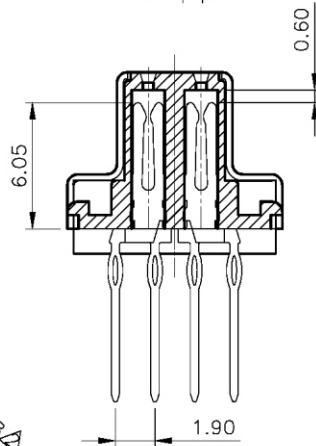
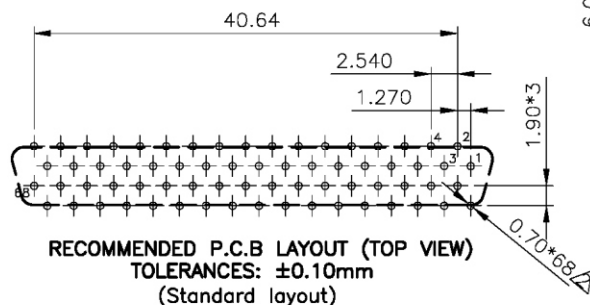
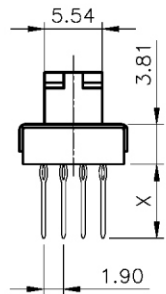
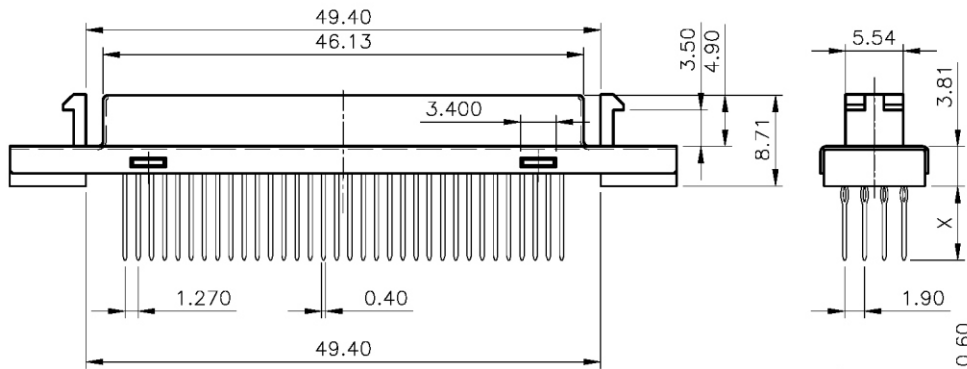

**SHELL & PIN LENGTH
DIM FOR "X"**

| P/N | 6. | DIM |
|-----|----|------|
| E | | 7.11 |
| F | | 4.39 |

SCALE 2:1

HPD-SP-068-LF

LEADFREE

RoHS Compliant



PART NO. **HPD-SP-068**

DWG NO. **HPD-SP-068**

FILE NO.

UNIT / mm

SCALE 1:1

CHECKED BY CY

DRAWING BY

PROJECTION

TOLERANCES ARE

.X ± 0.2
.XX ±
.XXX ±
AWG

DESCRIPTION:

AREA

REVISIONS

HK

DATE

焯倫股份有限公司