

**FEATURES:**

- Half pitch 1.27mm(.050") series
- Centronic type female connector for P.C.B straight dip solder type
- Panel mount receptacle assemblies bracket with latch block
- Die-Cast body provide EMI/RFI shielded

**MATERIALS:**

- Housing: Plastic thermoplastic P.B.T UL94V-0 black
- Contact: Phosphor bronze gold selective plated
- Bracketshell: Die-Cast Zinc Nickel plated over copper

**ELECTRICAL:**

- Current Rating: 1 Amp
- Insulation Resistance: 500MΩ/Min
- Withstanding Voltage: 500V AC/Min
- Contact Resistance: 35mΩ Max
- Temperature Range: -55°C ~ +105°C

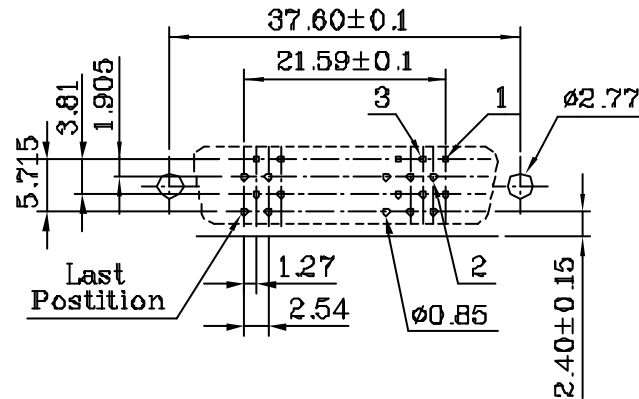
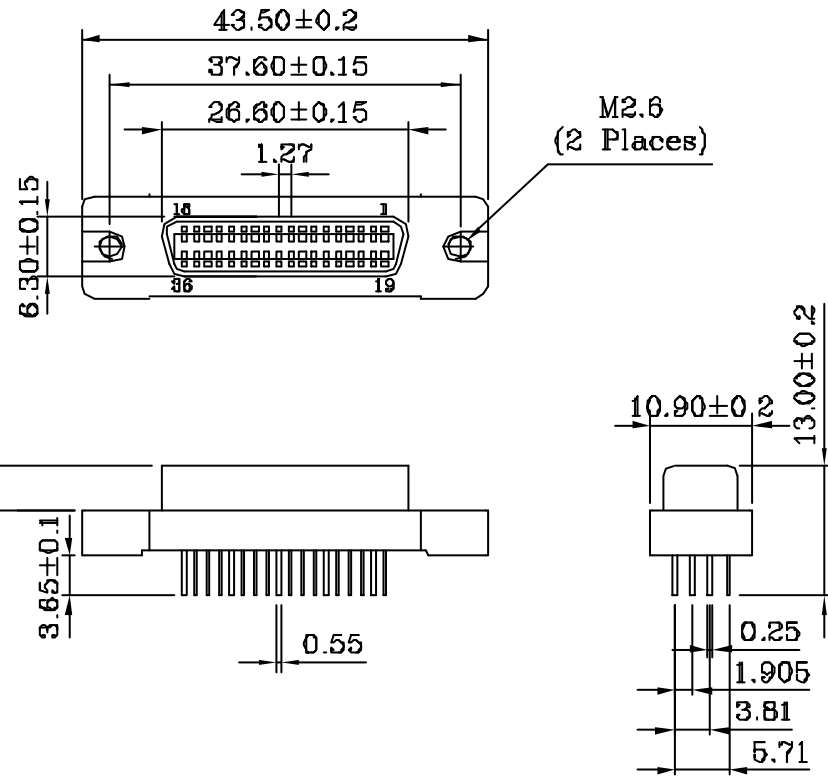

PC Board Mounting Dimensions



PART NO. <b>HPC-SDX-036</b>		CHECKED BY <b>CY</b>		TOLERANCES ARE		DESCRIP TION: <b>1.27mm(.050") Pitch Centronic 36F Female Connector Straight Dip Solder Type</b>	
DWG NO. <b>HPC-SDX-036</b>		DRAWING BY		.X±		AREA	
FILE NO.		PROJECTION		.XX±		REVISIONS	
UNIT / mm		SCALE 1:1		.XXX±		HK	
				AWG		DATE	

煜倫有限公司