

**FEATURES:**

- Half pitch 1.27mm(.050") series
- Centronic type female connector for P.C.B straight dip solder type
- Panel mount receptacle assemblies bracket with latch block
- Die-Cast body provide EMI/RFI shielded

**MATERIALS:**

- Housing: Plastic thermoplastic P.B.T UL94V-0 black
- Contact: Phosphor bronze gold selective plated
- Bracketshell: Die-Cast Zinc Nickel plated over copper

**ELECTRICAL:**

- Current Rating: 1 Amp
- Insulation Resistance: 500MΩ/Min
- Withstanding Voltage: 500V AC/Min
- Contact Resistance: 35mΩ Max
- Temperature Range: -55°C ~ +105°C

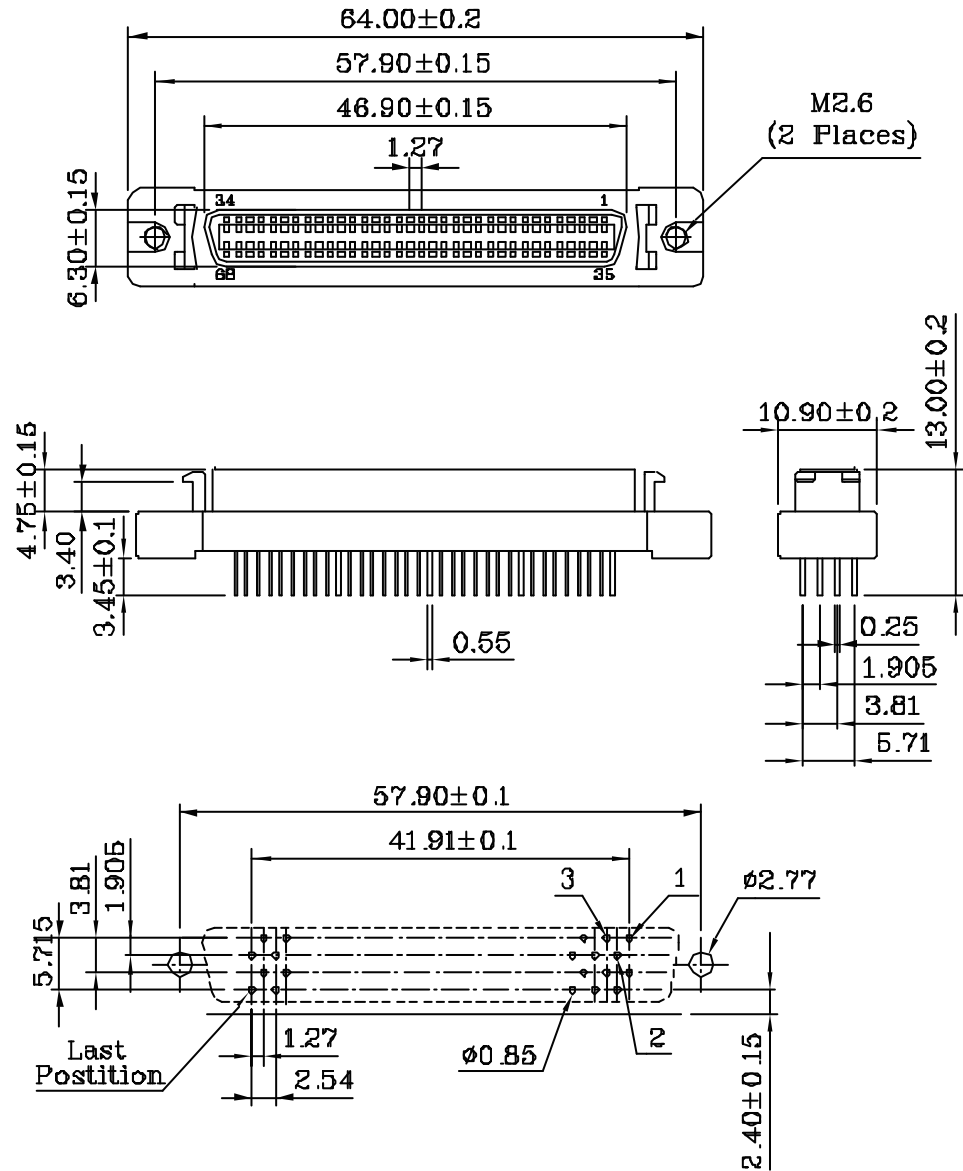

PC Board Mounting Dimensions

**RoHS Compliant**

TOLERANCES ARE

**MORETHANALL**  
PCB CONNECTORS  
Cable ASSEMBLIES

DRAWING BY CY

CHECKED BY GENIUS

UNIT/mm SCALE 1:1

DATE

SIZE A4

X, ±  
.X ±  
.XX ±  
.XXX ±  
ANG ±

PJECTION

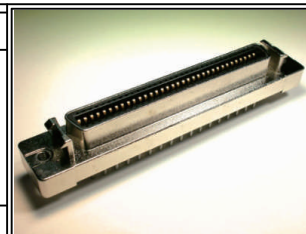

**ORDER INFORMATION**

**HPC-SDL-068-LF**

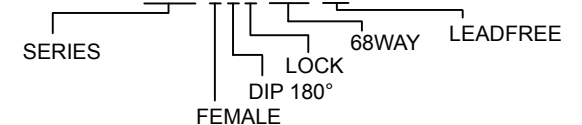

煜倫股份有限公司

www.morethanall.com

DESCRIPTION: 1.27mm(.050") Pitch Centronic 68P Female Connector Straight Dip Solder Type