

MATERIAL

INSULATOR: GLASS-REINFORCED THERMOPLASTIC.

CONTACT: COPPER ALLOY.

PLATING: MATING AREA - GOLD FLASH GOLD OVER NICKEL.
SOLDER AREA - TIN/LEAD OVER NICKEL.

ELECTRICAL

VOLTAGE RATING: 250 VAC RMS.

CURRENT RATING: 1 AMP.

DIELECTRIC WITHSTANDING VOLTAGE: 500 VAC RMS 60Hz
FOR 1 MINUTE.

INSULATION RESISTANCE: 1000 MEGOHMS MIN AT 500 VDC.

CONTACT RESISTANCE: 30 MILLIOHMS MAX.

MECHANICAL

RETENTION FORCE: 460 GRAMS MIN PER CONTACT.

INSERTION FORCE: 230 GRAMS MAX PER CONTACT PAIR.

WITHDRAWAL FORCE: 15 GRAMS MIN PER CONTACT PAIR.

ENVIRONMENTAL

TEMPERATURE RANGE: -55°C TO +85°C.

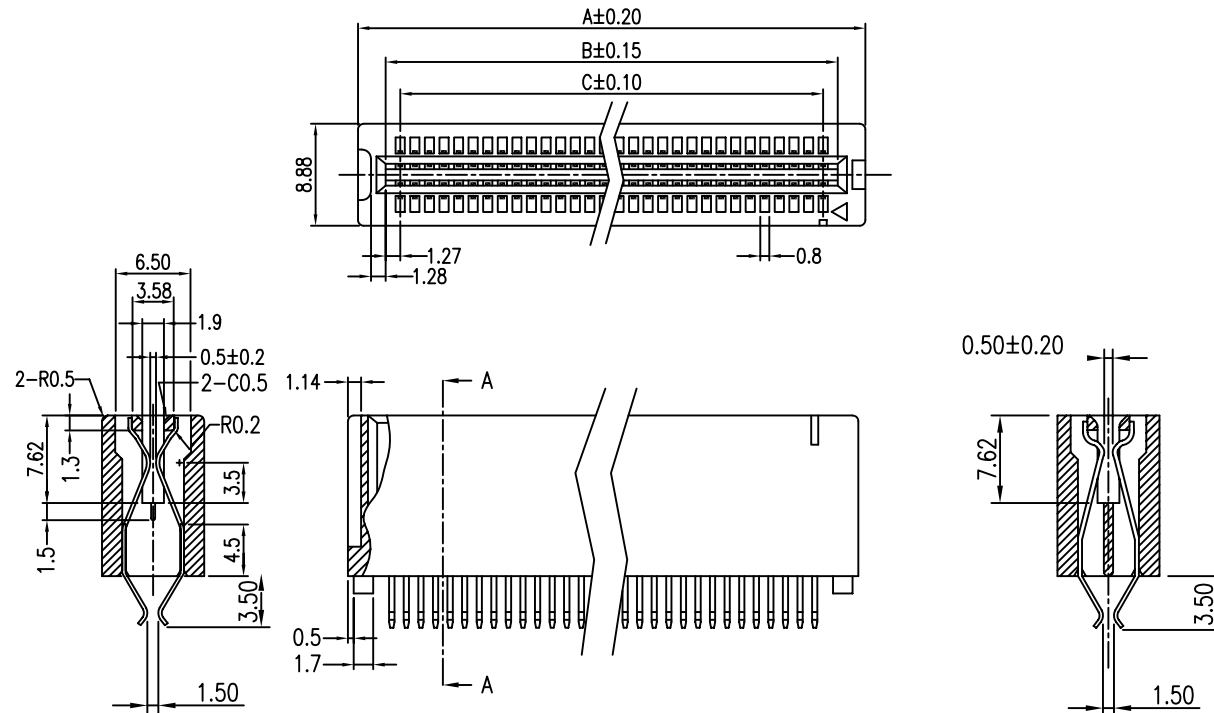

SECTION A-A

Circuit	Dimension			Circuit	Dimension		
	A	B	C		A	B	C
04	8.64	3.81	1.27	38	30.23	25.40	22.86
06	9.91	5.08	2.54	40	31.50	26.67	24.13
08	11.18	6.35	3.81	42	32.77	27.94	25.40
10	12.45	7.62	5.08	44	34.04	29.21	26.67
12	13.72	8.89	6.35	46	35.31	30.48	27.94
14	14.99	10.16	7.62	48	36.58	31.75	29.21
16	16.26	11.43	8.89	50	37.85	33.02	30.48
18	17.53	12.70	10.16	52	39.12	34.29	31.75
20	18.80	13.97	11.43	54	40.39	35.56	33.02
22	20.07	15.24	12.70	56	41.66	36.83	34.29
24	21.34	16.51	13.97	58	42.93	38.10	35.56
26	22.61	17.78	15.24	60	44.20	39.37	36.83
28	23.88	19.05	16.51				
30	25.15	20.32	17.78				
32	26.42	21.59	19.05				
34	27.69	22.86	20.32				
36	28.96	24.13	21.59				

RoHS Compliant

TOLERANCES ARE

MORETHANALL
PCB CONNECTORS
Cable ASSEMBLIES

DRAWING BY CY

CHECKED BY GENIUS

UNIT / mm

SCALE 1 : 1

DATE

SIZE A4

PJECTION

0-10 ± 0.2
30-100 ± 0.4
100-300 ± 0.5
AWG

照片框

ORDER INFORMATION

HE-E-xxx-LF
SERIES | LEADFREE
004-060 WAY
EDGE

煜倫股份有限公司

www.morethanall.com

DESCRIPTION: 1.27 PITCH WITH MOUNTING EAR