

MATERIAL

INSULATOR: GLASS-REINFORCED THERMOPLASTIC.
 CONTACT: COPPER ALLOY.
 PLATING: MATING AREA - SELECTED GOLD OVER NICKEL.
 SOLDER AREA - TIN OVER NICKEL.

ELECTRICAL

VOLTAGE RATING: 250 VAC RMS.
 CURRENT RATING: 1 AMP.
 DIELECTRIC WITHSTANDING VOLTAGE: 500 VAC RMS 60Hz
 FOR 1 MINUTE.
 INSULATION RESISTANCE: 1000 MEGOHMS MIN AT 500 VDC.
 CONTACT RESISTANCE: 30 MILLIOHMS MAX.

MECHANICAL

RETENTION FORCE: 460 GRAMS MIN PER CONTACT.
 INSERTION FORCE: 230 GRAMS MAX PER CONTACT PAIR.
 WITHDRAWAL FORCE: 15 GRAMS MIN PER CONTACT PAIR.

ENVIRONMENTAL

TEMPERATURE RANGE: -55°C TO +85°C.

HE-E-010K1-LF

LEADFREE

RoHS Compliant

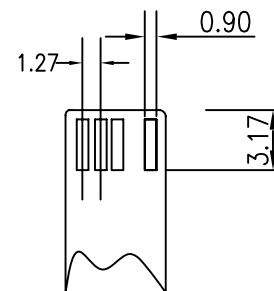
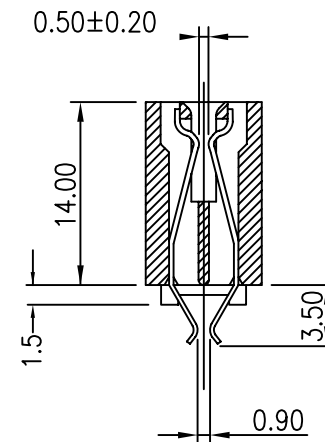
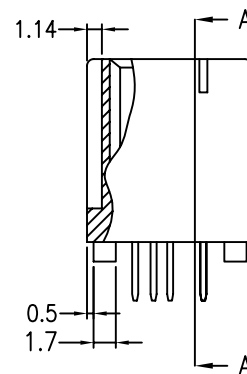
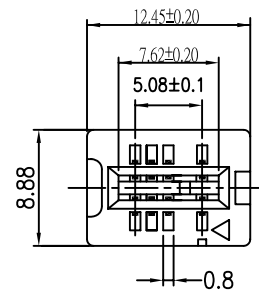

RECOMMENDED PCB LAYOUT



PART NO. HE-E-010K1

DWG NO. HE-E-010K1

FILE NO.

UNIT / mm

SCALE 1:1

CHECKED BY CY

DRAWING BY

PROJECTION

TOLERANCES ARE

.X ± 0.2
.XX ±
.XXX ±
AWG

DESCRIPTION:

AREA REVISIONS HK DATE

焜倫股份有限公司