

Any Alternative Parts MUST be approved by Customer.

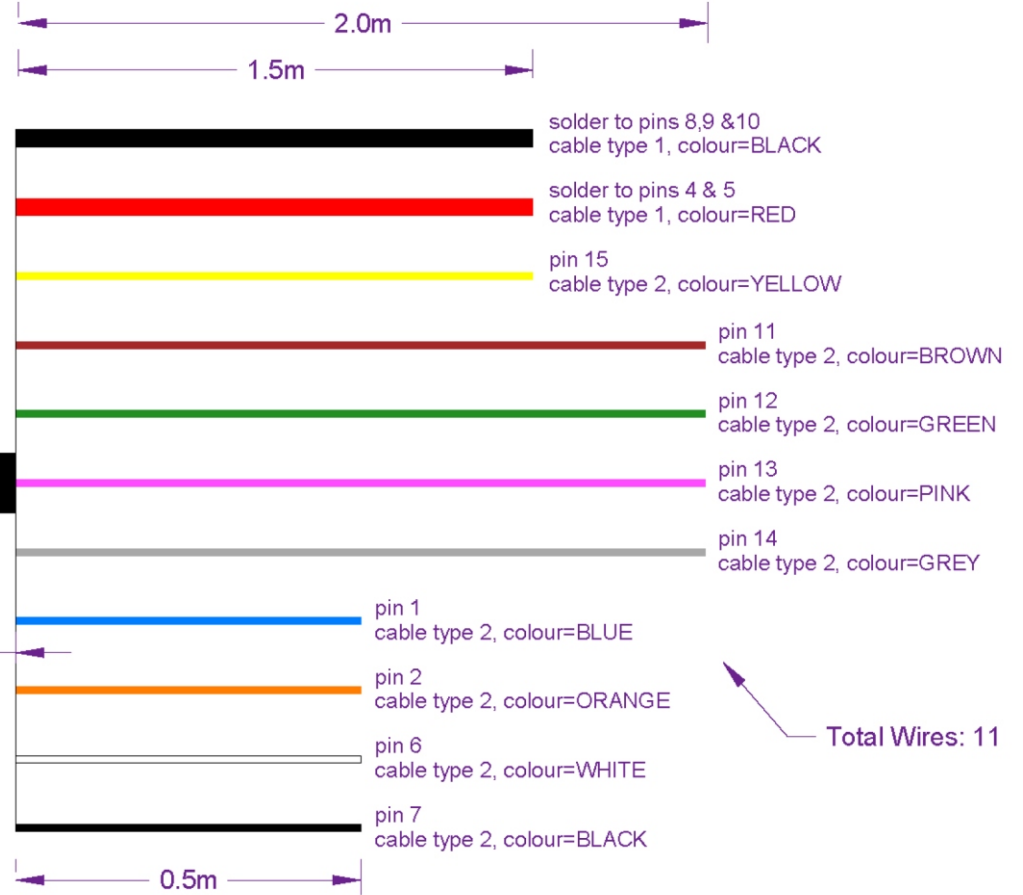
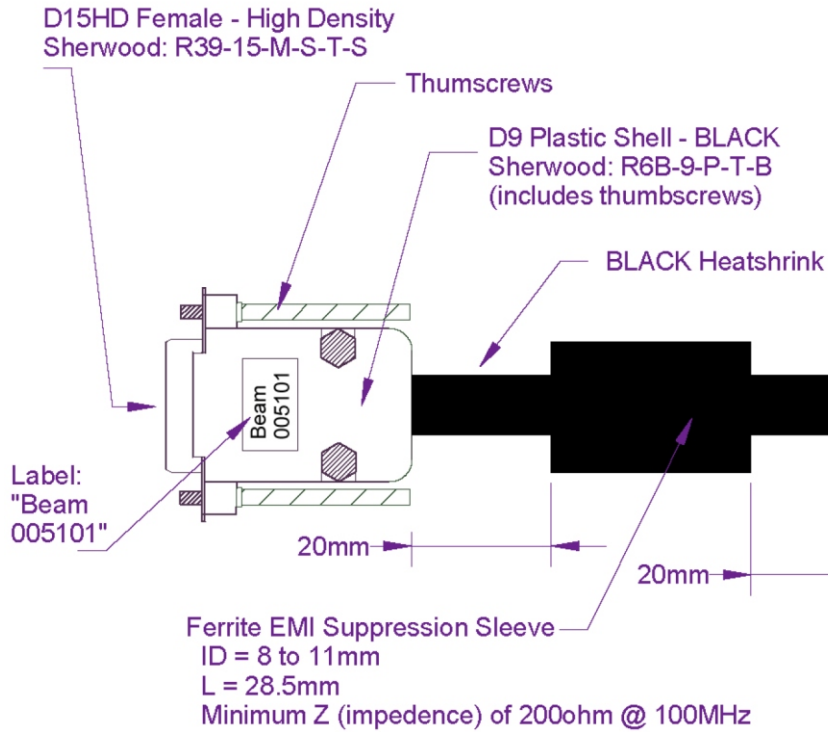

**CABLE TYPE 1:**

CSA = 0.75mm<sup>2</sup>  
 Current >= 4.5A or higher  
 Voltage >= 600V or higher  
 Resistance < 25ohm/km  
 Insulation = PVC,  
 thickness = >0.5mm  
 Temperature Range:  
 <= -30degC, >= +80degC  
**RoHS COMPLIANT!!**

**CABLE TYPE 2:**

CSA = 0.35mm<sup>2</sup>  
 Voltage >= 600V or higher  
 Resistance < 80ohm/km  
 Insulation = PVC,  
 thickness = >0.4mm  
 Temperature Range:  
 <= -30degC, >= +80degC  
**RoHS COMPLIANT!!**

**HDX1-1500-M2M07-LF**  
**LEADFREE**

**RoHS Compliant**



PART NO. **HDX1-1500-M2M07**

DWG NO. **HDX1-1500-M2M07**

FILE NO.

UNIT / mm

SCALE 1:1

CHECKED BY CY

DRAWING BY

PROJECTION

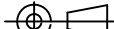

TOLERANCES ARE

.X ± 0.2  
 .XX ±  
 .XXX ±  
 AWG

DESCRIPTION:

AREA

REVISIONS

HK

DATE

焯倫股份有限公司