

1 2 3 4 5 6 7 8 9 0

J
I
H
G
F
E
D
C
B
A

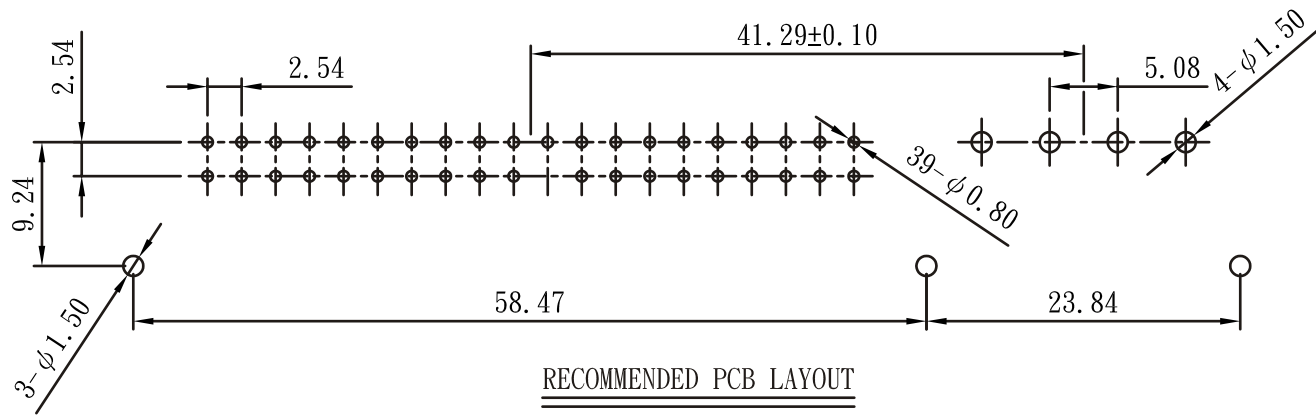
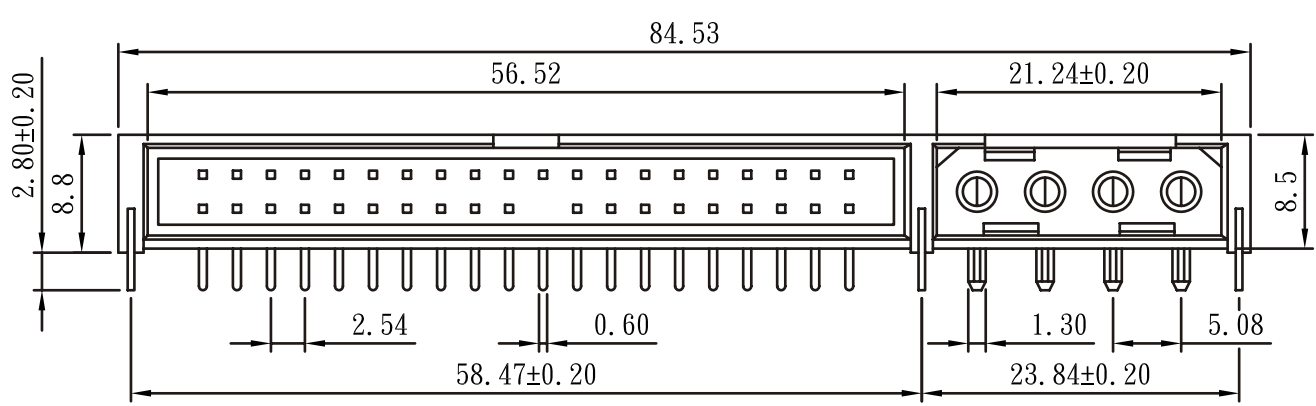
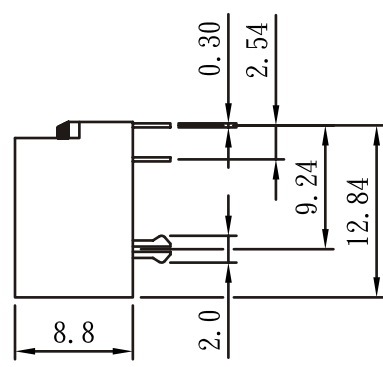
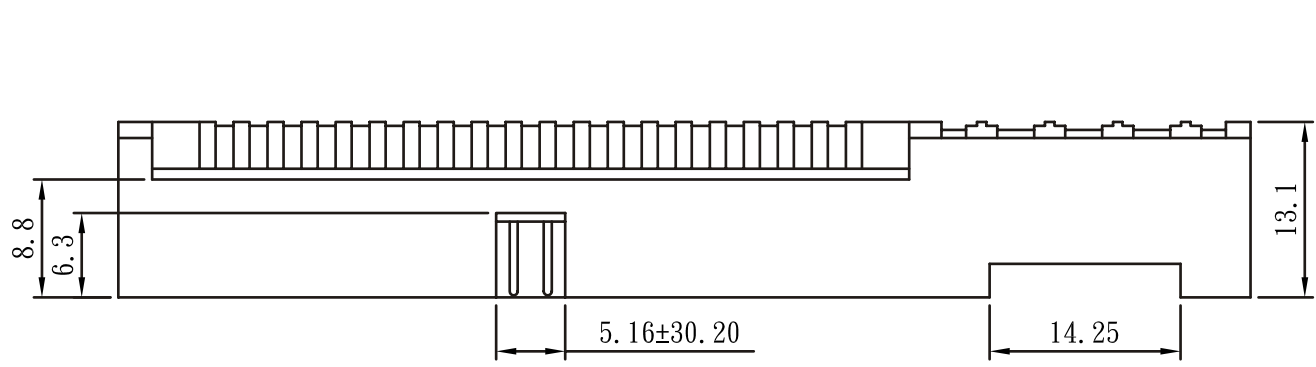

SPECIFICATIONS:
ELECTRICAL CHARACTERISTICS:
 CONTACT CURRENT RATING: 1 AMPERES
 DIELECTRIC WITHSTANDING VOLTAGE: AC 600V/60SEC. R. M. S.
 INSULATION RESISTANCE: 1000 MEGOHMS MINIMUM AT DC 500V
 CONTACT RESISTANCE: 25 MILLIOHMS MAXIMUM
MECHANICAL CHARACTERISTICS:
 DURABILITY: 100 CYCLES MIN.
 MATING FORCE: 180GF PER CONTACT MAX.
 EXTRACTION FORCE: 30GF PER CONTACT MIN.
 CONTACT RETENTION FORCE: 500GF PER CONTACT MIN.
MATERIALS:
 CONTACTS: PHOSPHOR BRASS
 INSULATOR: PPS UL94V-0 RATED
FINISHES:
 CONTACT: GOLD OVER NICKEL
 TERMINAL FINISH: TIN-LEAD OVER NICKEL
ENVIRONMENTAL:
 OPERATING TEMPERATURE: -55°C TO +105°C

RECOMMENDED PCB LAYOUT



PART NO. **HC-R-0201**

DWG NO. **HC-R-0201**

FILE NO.

UNIT / mm

SCALE 1:1

CHECKED BY CY

DRAWING BY

PROJECTION

TOLERANCES ARE

.X±
.XX±
.XXX±
AWG

DESCRIPTION: **2in1 COMBO CONNECTOR, STRAIGHT PIN**

AREA	REVISIONS	HK	DATE
------	-----------	----	------

煜倫有限公司