

1 2 3 4 5 6 7 8 9 0

J  
I  
H  
G  
F  
E  
D  
C  
B  
A

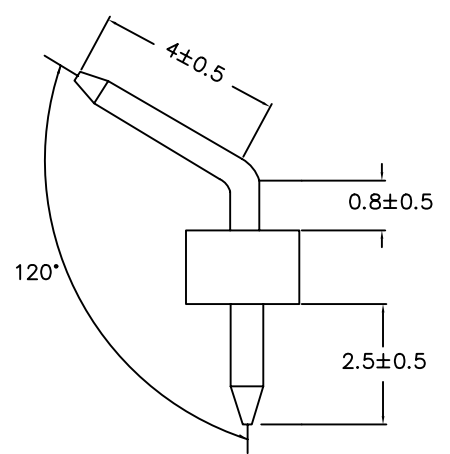

H-ATNL-1X04-LF  
 NL: NYLON LF: LEADFREE

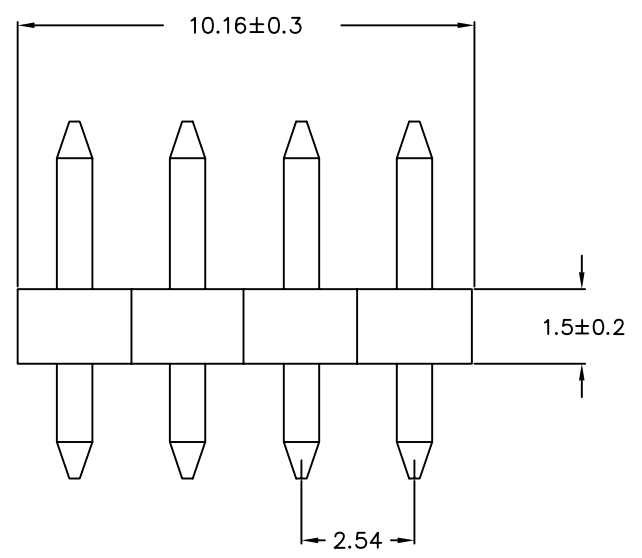
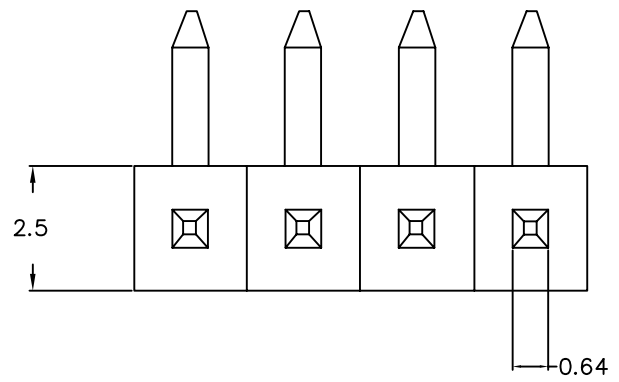
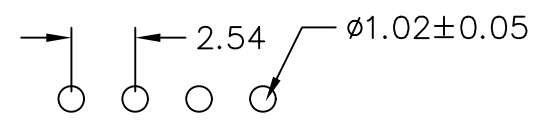

Recommended P.C.B Layout

MATERIAL

Insulator : 30% Glass fiber PBT  
 Contact Pin : Brass

SPECIFICATION

Current Rate : 3 AMP  
 Insulation Resistance : 5000MΩMin. at DC 500V  
 Contact Resistance : 20mΩMax. at DC 100mA  
 Dielectric Voltage : AC 500V for one minute  
 Operation Temperature : -40°C to + 105°C



PART NO. H-AT-1X04

DWG NO. H-AT-1X04

APPROVED BY CY

TOLERANCES ARE

DESCRIPTION:

FILE NO.

DRAWING BY

.X ± 0.3  
.XX ± 0.2  
.XXX  
AWG

煜倫股份有限公司

UNIT / mm

SCALE 1:1

PROJECTION

AREA

REVISIONS

HK

DATE