

**SPECIFICATION**

1. Rating : DC 30V , 1.0A
2. Contact resistance :  $\leq 30m\Omega$
3. Insulation resistance :  $\geq 100M\Omega$
4. Withstand voltage : 500VAC
5. Insertion and extraction force : 3-20N
6. life test : 5,000 cycles

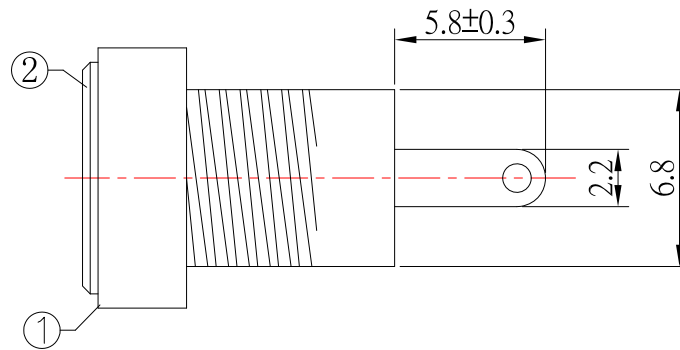
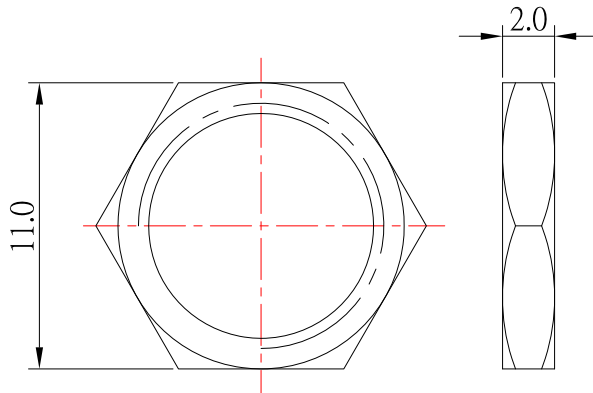

MODEL NO.	DCJ-SPACKN-xx
SCHEMATIC	4 (3)
	5
CENTER PIN	Ø2.0mm
	Ø2.5mm

NO.	DESCRIPTION	QTY	MATERIAL	PLATING
⑤	SPRING	1	PHOSPHOR BRONZE	Ag-Plating
④	CONTACT FOOT	1	BRASS	Ag-Plating
③	PIN	1	BRASS	Ni-Plating
②	AXIS SUPPORT	1	BRASS	Ni-Plating
①	HOUSING	1	PBT	

**RoHS Compliant**

TOLERANCES ARE

**MORETHANALL**  
PCB CONNECTORS  
Cable ASSEMBLIES

煜倫股份有限公司

www.morethanall.com

DRAWING BY CY

CHECKED BY GENIUS

UNIT / mm

SCALE 1 : 1

DATE

SIZE A4

PJECTION

Up to 5 ±0.2  
Above 5 ~ 15 ±0.3  
Above 15 ~ 30 ±0.4  
Above 30 ~ 50 ±0.5  
Angle ±0.3°



**ORDER INFORMATION**

DCJ-SPACKN-xx-LF

SERIES | | | | | LEADFREE  
20:2.00  
25:2.50  
SOLDER NUT  
PANEL FRONT BLACK  
C TYPE

DESCRIPTION: JACK