

LOCK WASHER

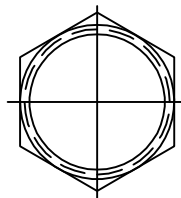

1/2-28 NUT

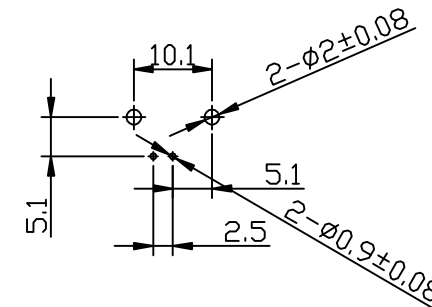
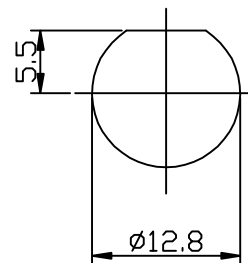

RECOMMENDED MOUNTING HOLE
 MAXIMUM PANEL THICKNESS: 5.5MM
 RECOMMENDED MOUNTING TORQUE:
 12 INCH-POUNDS MAX

NO	DESCRIPTION	MATERIAL	FINISH	QTY
7	NUT	BRASS	NICKEL	
6	WASHER	IRON	NICKEL	1
5	PIN	COPPER	TIN	1
4	PIN	COPPER	TIN	1
3	INSULATOR	PDM	NONE	1
2	BODY	ZINC ALLOY	NICKEL	1
1	CENTER CONTACT	PHOSPHOR BRONZE	GOLD	1

RoHS Compliant

TOLERANCES ARE

MORETHANALL
 PCB CONNECTORS
 Cable ASSEMBLIES

煜倫股份有限公司

www.morethanall.com

DRAWING BY CY

CHECKED BY GENIUS

UNIT / mm

SCALE 1 : 1

DATE

SIZE A4

P PROJECTION

0.5-5	±0.2
6-30	±0.4
30-120	±0.6
120-315	±1
315-1000	±1.6
1000-2000	±2.4



ORDER INFORMATION

BNC-JR15WFM-xx-LF
 SERIES | JACK | DIP 90° | LEADFREE | 50:50 OHM | 75:75 OHM | FULL METAL | WASHER+NUT | HIGH 15.8mm

DESCRIPTION: BNC CONNECTOR, PCB/PANEL MOUNT JACKS