

**FEATURES:**

- Half pitch 1.27mm(.050") series
- D-SUB type female connector for P.C.B straight Dip solder type
- receptacle assemblies bracket with latch block and without latch block

**MATERIALS:**

- Housing: Plastic thermoplastic P.B.T UL94V-0 black
- Contact: Phosphor bronze gold selective plated over Tin
- Bracketshell: Die-Cast Zinc Nickel plated over copper

**ELECTRICAL:**

- Current Rating: 1 Amp
- Insulation Resistance: 500MΩ/Min
- Withstanding Voltage: 500V AC/Min
- Contact Resistance: 35mΩ Max
- Temperature Range: -55°C ~ +105°C

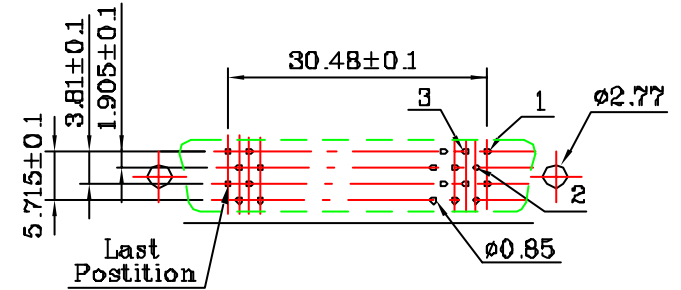
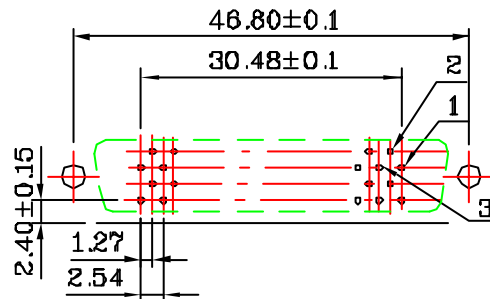
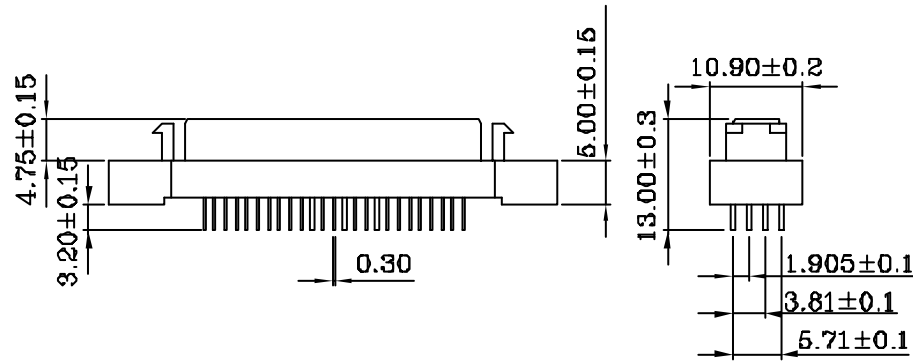
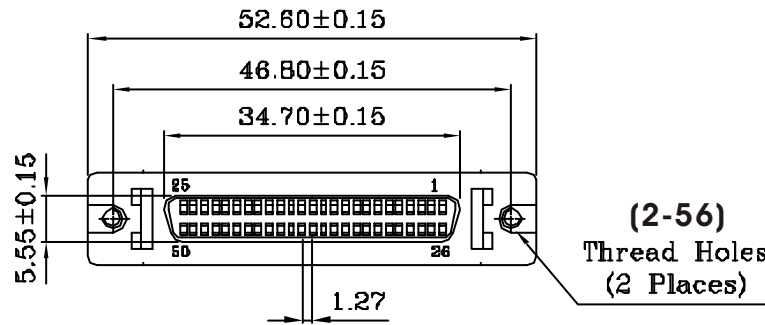

**MORE THAN ALL**  
CONNECTORS  
ASSEMBLIES

PART NO. **HPD-SDL-050**

DWG NO. **HPD-SDL-050**

FILE NO.

UNIT / mm

SCALE 1:1

CHECKED BY CY

DRAWING BY

PROJECTION

TOLERANCES ARE

.X ± 0.2  
.XX ±  
.XXX ±  
AWG

DESCRIPTION:

1.27mm(.050") Pitch D-SUB 50P Female  
Connector Straight Dip Solder Type

AREA

REVISIONS

HK

DATE

煜倫股份有限公司