

CIRCUIT without CARD

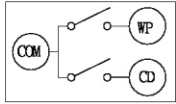

CARD INSERTED

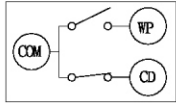

● Write Protect SW. : Lock
● Status: Read only

CARD INSERTED

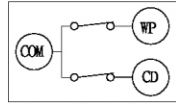

● Write Protect SW. : Unlock
● Status: Write enable

Notes: (1). Material:

Insulator: LCP+30% G.F., UL 94V-0 rated, Color Black.
Contact: Phosphor Bronze

(2). Plating:

Contact Area: Hard gold plating over 1.27 μ m(50 μ)min Nickel underplating.
Soldering Zone: 3.05 μ m(120 μ)min.100% Tin, or Lead-free plating per part number designation, over Nickel underplating.
Underplating: 1.27 μ m (50 μ)min. Nickel alloy.

SDC-W24PB20Bxx-09-LF

LEADFREE

RoHS Compliant

TABLE 1

料號	Standoff	"L"
SDC-W24PB20B00-09	0.0mm	2.75mm
SDC-W24PB20B15-09	1.5mm	4.25mm
SDC-W24PB20B18-09	1.8mm	4.55mm
SDC-W24PB20B20-09	2.0mm	4.75mm

Recommended P.C.Board Layout-STYLE 1

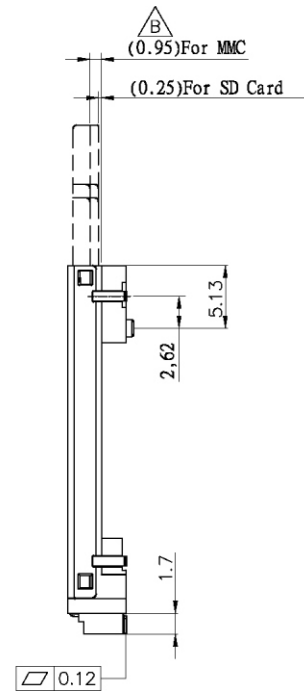
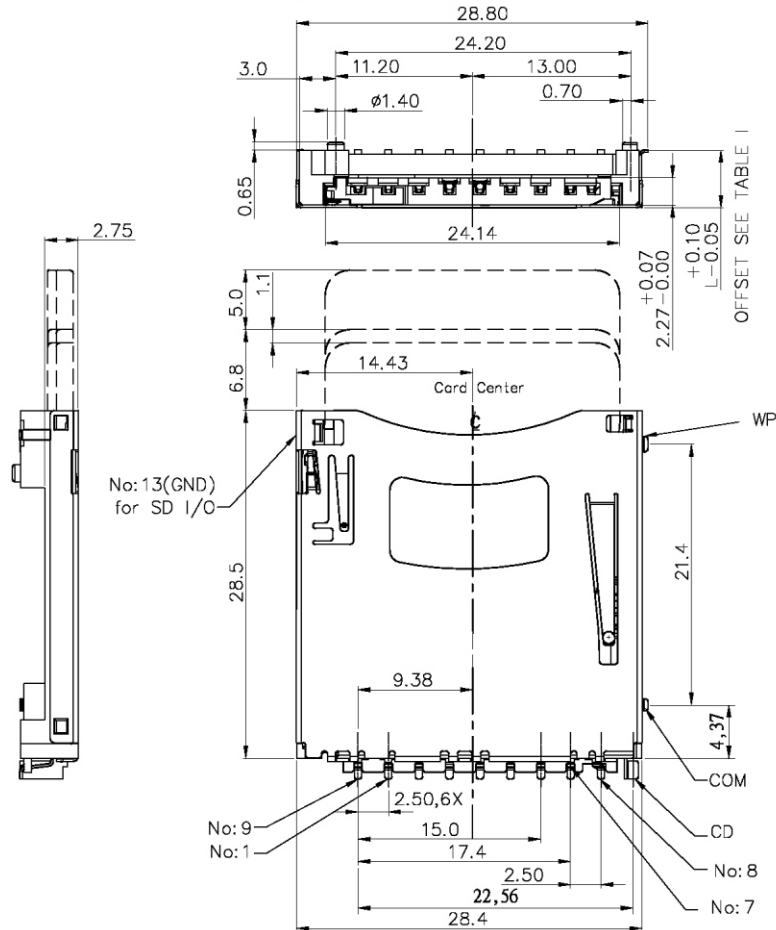
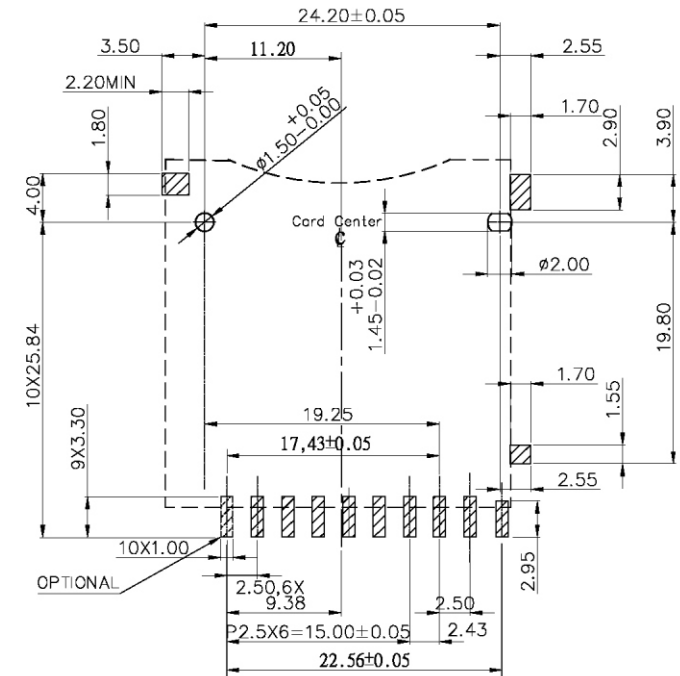

MORETHANALL
CONNECTORS
ASSEMBLIES

PART NO. SDC-W24PB20Bxx-09

DWG NO. SDC-W24PB20Bxx-09

FILE NO.

UNIT / mm

SCALE 1:1

CHECKED BY CY

DRAWING BY

PROJECTION

TOLERANCES ARE

.X \pm 0.2
.XX \pm
.XXX \pm
AWG

DESCRIPTION:

AREA

REVISIONS

HK

DATE

煜倫股份有限公司