

DIMENSION

A	$(N-1) \times 3.81 + 4.6$
B	$(N-1) \times 3.81$

N=Number of contacts

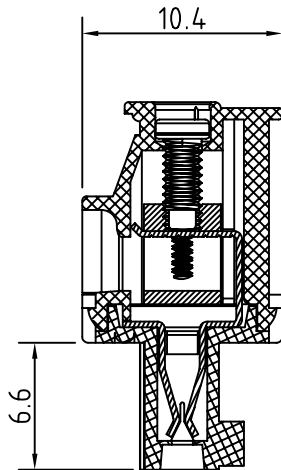
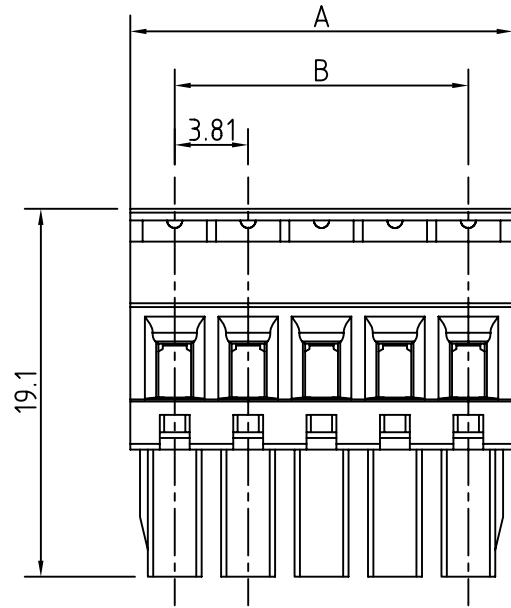

Technical Data:

Material:

- Contact(metal housing): Brass Machined(Option)
- Terminal screw: Steel Galvanized and chromitized or Nickel plated or Tin plated(standard)(optian)

- ⚠ ◦ Wire guard: PhBz, Tin plated.
- Insulator body(housing): Polyamide(Glass filled)(UL94V-0)

Electrical

- Voltage rating: 300VAC
- Current rating: 8 Amps/way max
- Contact resistance: 20mΩ(max)
- Insulation resistance: 5000MΩ/1000V

- ⚠ ◦ Withstanding Voltage: 2500VAC(1min) Test time=60sec/1pcs
- Wire range: 16-28AWG

Mechanical:

- Torque: 2kg-cm/M2
- ⚠ ◦ Operating temperature: -40°C to +120°C
- Soldering temperature= 250°C/5 seconds max

RoHS Compliant

TOLERANCES ARE

**MORETHANALL**  
PCB CONNECTORS  
Cable ASSEMBLIES

煜倫股份有限公司

www.morethanall.com

DRAWING BY CY

CHECKED BY GENIUS

UNIT / mm

SCALE 1 : 1

DATE

SIZE A4

X, ±  
.X ± 0.30  
.XX ± 0.10  
.XXX ±  
ANG ±

PJECTION



ORDER INFORMATION

TBH038-SVCB-xx-LF  
SERIES | | | LEADFREE  
| | | 02~24WAY  
| | | BOTTOM SIDE  
| | | CAGE  
| | | SCREW 180°  
| | | FEMALE

DESCRIPTION: 3.81mm Series(for latch on back side)