

P.C.B LAYOUT

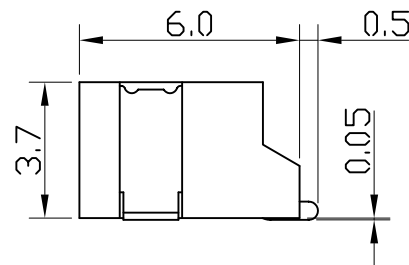
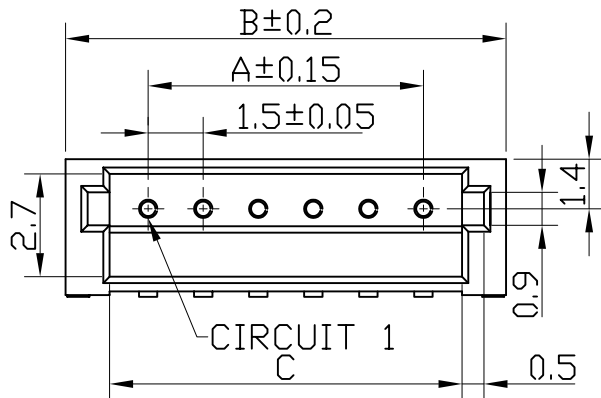

SPECIFICATION:

PITCH BETWEEN POLES : 1.5mm

CURRENT RATING : 1A AC/DC

VOLTAGE RATING : 50V AC/DC

CONTACT RESISTANCE : 20mohm (max.)

INSULATION RESISTANCE : 500Mohm MIN

WITHSTAND VOLTAGE : 500V AC/MINUTE

TEMPERATURE RANGE : -25°C TO +85°C

FEATURES:

AVAILABLE NUMBER OF CIRCUITS : 2 TO 13

MATERIAL : NYLON 9T UL 94V-0

CONTACT : 0.50mm(.020") ROUND PIN,
BRASS , TIN PLATED

Dimensional and Order Information

Poles	DIM:(mm)		
	A	B	C
2	1.50	6.00	3.60
3	3.00	7.50	5.10
4	4.50	9.00	6.60
5	6.00	10.50	8.10
6	7.50	12.00	9.60
7	9.00	13.50	11.10
8	10.50	15.00	12.60
9	12.00	16.50	14.10
10	13.50	18.00	15.60
11	15.00	19.50	17.10
12	16.50	21.00	18.60
13	18.00	22.50	20.10



PART NO. **ZH-W-xx**

DWG NO. **ZH-W-xx**

CHECKED BY CY

TOLERANCES ARE

DESCRIPTION: 1.5mm ZH 90° SMT

FILE NO.

DRAWING BY

.X ± 0.2
.XX ±
.XXX ±
AWG

AREA

REVISIONS

HK

DATE

煜倫股份有限公司

UNIT / mm

SCALE 1:1

PROJECTION

