

NOTES

***Material:**

Body: Nylon66,Glass Fiber 30%,
 UL 94V-0 Rated. Color: White,Black, CAV. NO.:A~H.
 Contacts: Brass.
 Plating: Gold Plating Over Nickel on Contact Area; Tin/Lead Plating on Terminal.

***Mechanical:**

Insertion Force: 1.15N Max Per Contact Pair;
 Withdrawal Force: 0.15N Min Per Contact Pair;
 Contact Retention Force: 4.9N Min Per Contact;

***Electrical Specification:**

Contact Resistance: 30 Milliohms Max.
 Current Resistance: 1.1 Ampere
 Insulation Resistance: 1000 Megohms Min, At 500V AC.
 Operating Temperature: -55°c to +105°c

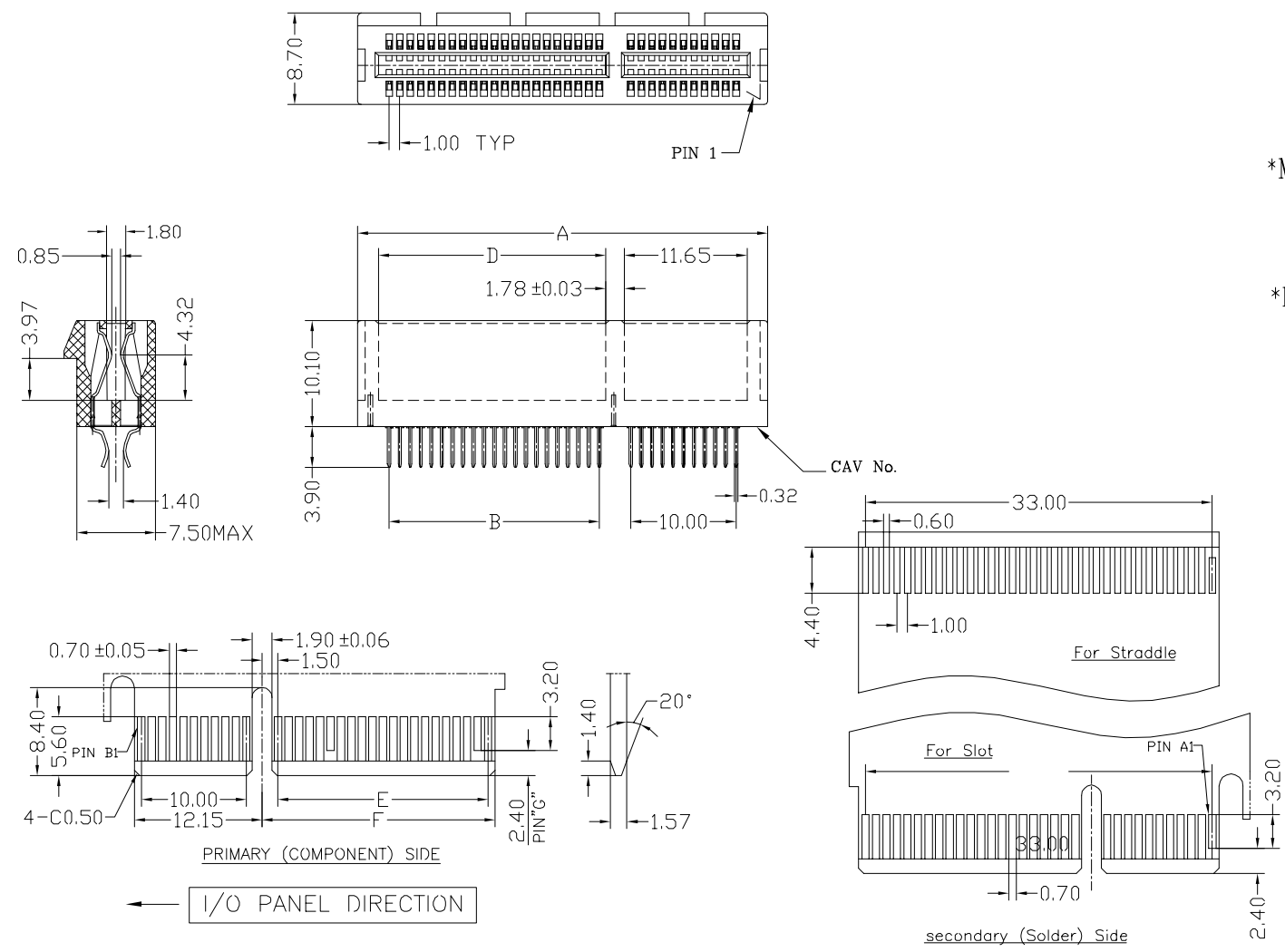

Dimension Manual

No. of Contacts	DIM 'A'	DIM 'B'	DIM 'C'	DIM 'D'
36	25.00	6.00	9.15	7.65
64	39.00	20.00	23.15	21.65
98	56.00	37.00	40.15	38.65
164	89.00	70.00	73.15	71.65

No. of Contacts	DIM 'E'	DIM 'F'	PIN 'G'
36	6.00	8.15	B17
64	20.00	22.15	B17,B31
98	37.00	39.15	B17,B31 B48
164	70.00	72.15	B17,B31 B48,B81



PART NO. PCIX-E-xxx		CHECKED BY CY		TOLERANCES ARE		DESCRIP TION:							
DWG NO. PCIX-E-xxx		DRAWING BY		.X ± .XX ± .XXX ± AWG									
FILE NO.		PROJECTION				AREA		REVISIONS		HK		DATE	
UNIT / mm	SCALE 1:1												

煜倫有限公司