

NOTES:

1. MATERIAL: INSULATOR: LCP UL94V-0
CONTACT: PHOSPHOR BRONZE
SHELL: Ni-Ag ALLOY
2. CONTACT FINISH: 1. 5u" MIN. GOLD ON CONTACT. TIN ON SOLDER TAIL. BOTH OVER NICKEL.(LEADFREE MATTE)
2. 15u" MIN. GOLD ON CONTACT. TIN ON SOLDER TAIL. BOTH OVER NICKEL.(LEADFREE MATTE)
3. IMPORTANT AREA FLASH: 0.05mm MAX. DAMAGE: NA. DEFAEME: NA.
4. PACKING TYPE: 1.REEL 2. TRAY
5. INSPECTING POINT

FIX-WX23AR-30-LF
LEADFREE

RoHS Compliant

MORETHANALL
CONNECTORS
ASSEMBLIES

PART NO. FIX-WX23AR-30

DWG NO. FIX-WX23AR-30

CHECKED BY CY

TOLERANCES ARE

DESCRIP TION:

FILE NO.

DRAWING BY

.X ± 0.2
.XX ± 0.1
.XXX ±
AWG

AREA

REVISIONS

HK

DATE

煜倫股份有限公司

UNIT / mm

SCALE 1:1

PROJECTION

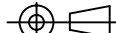

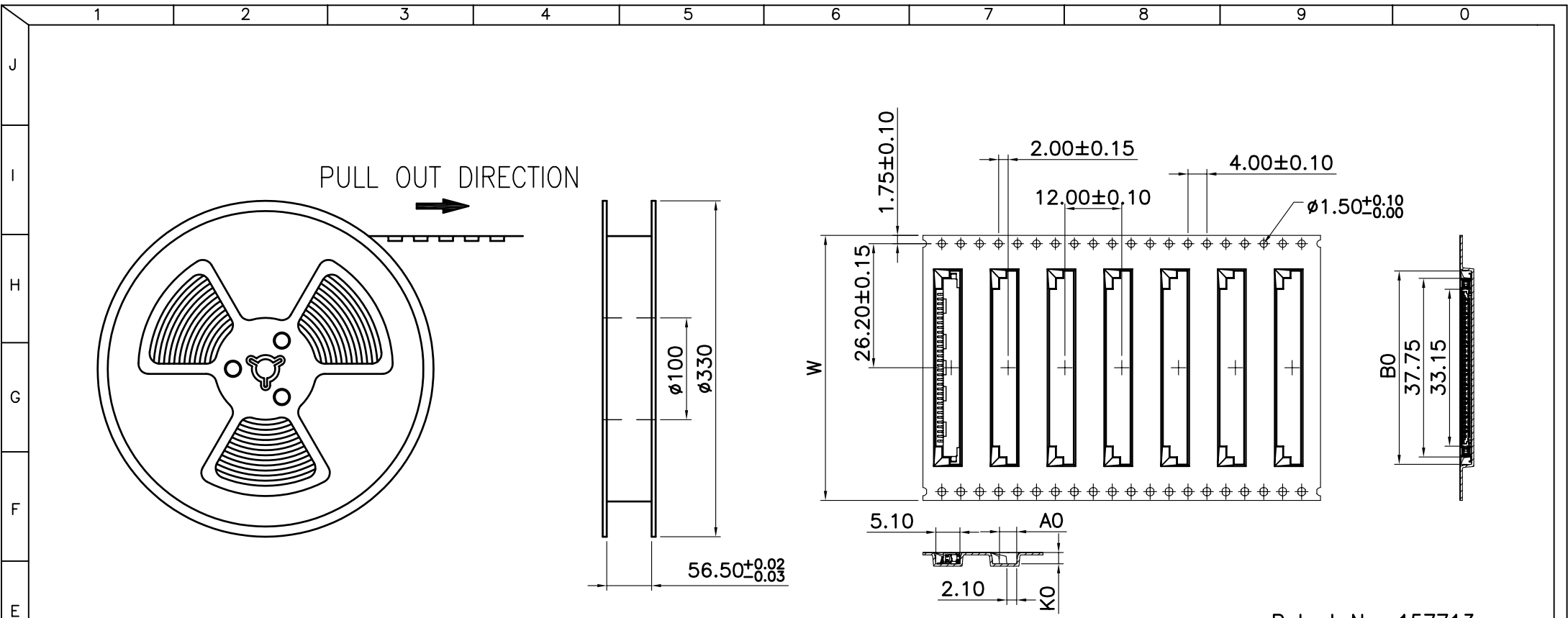

1. 10 sprocket hole pitch cumulative tolerance ± 0.20 .
2. Carrier camber is within 1 mm in 250 mm.
3. Material : Black Conductive Polystyrene Alloy
4. All dimensions meet EIA-481-C requirements.
5. Thickness : 0.30 ± 0.05 mm.
6. Component load per 13" reel : 2000 pcs.

Patent No. 157713

W	56.00 ± 0.30
A0	3.65 ± 0.10
B0	40.85 ± 0.10
K0	2.50 ± 0.10



PART NO. FIX-WX23AR-30

DWG NO. FIX-WX23AR-30

CHECKED BY CY

TOLERANCES ARE

DESCRIP TION:

FILE NO.

DRAWING BY

.X ± 0.2
.XX ± 0.1
.XXX \pm
AWG

煜倫股份有限公司

UNIT / mm

SCALE 1:1

PROJECTION

AREA

REVISIONS

HK

DATE

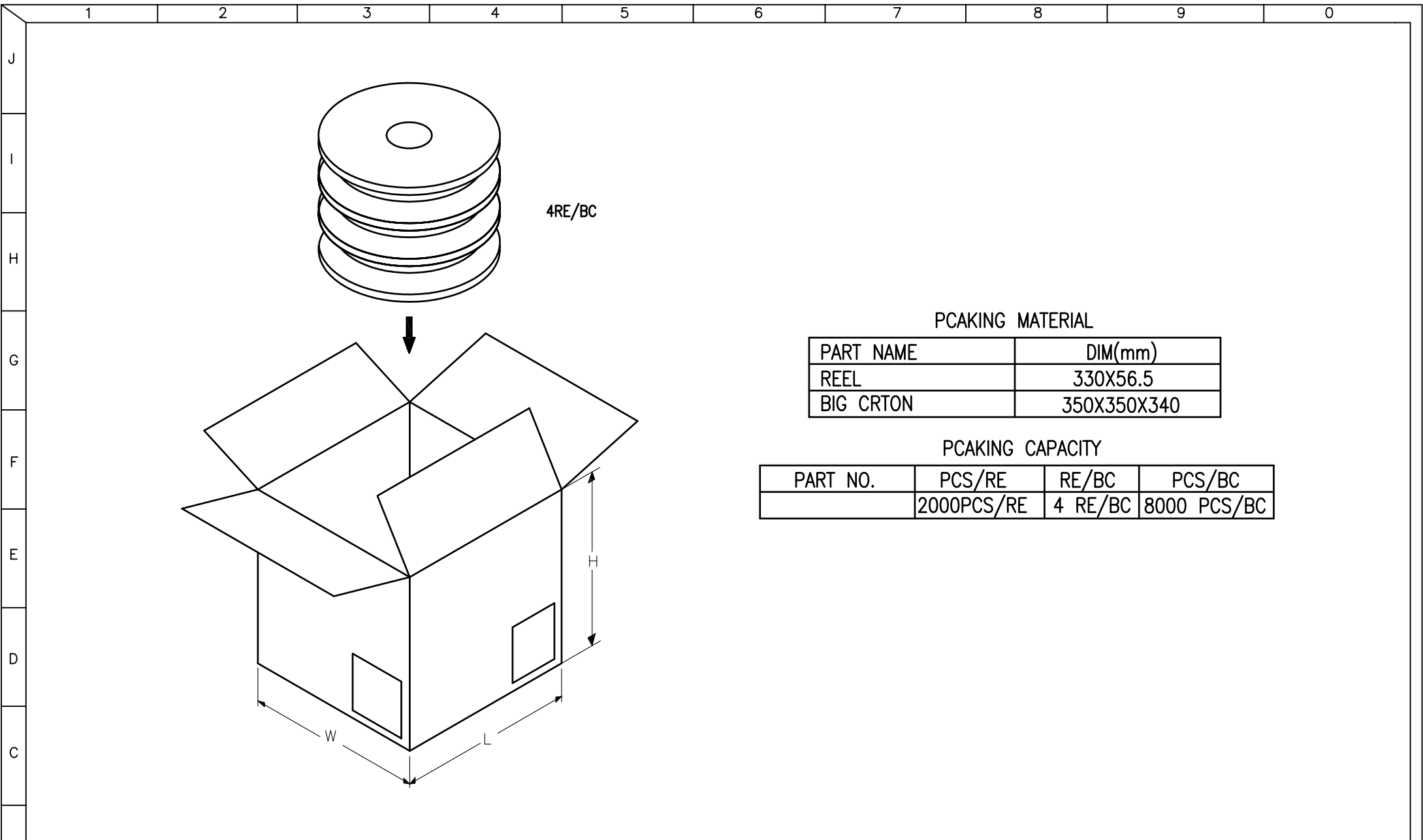

4RE/BC

PACKING MATERIAL

PART NAME	DIM(mm)
REEL	330X56.5
BIG CRTON	350X350X340

PACKING CAPACITY

PART NO.	PCS/RE	RE/BC	PCS/BC
	2000PCS/RE	4 RE/BC	8000 PCS/BC

B			PART NO. FIX-WX23AR-30		TOLERANCES ARE .X ± 0.2 .XX ± 0.1 .XXX ± AWG	DESCRIP TION:				
			DWG NO. FIX-WX23AR-30							CHECKED BY CY
A			FILE NO.		DRAWING BY	AREA	REVISIONS	HK	DATE	
			UNIT / mm	SCALE 1:1	PROJECTION					