

MATERIAL:

- HOUSING—DSM STANYL TE250F6 (NYLON-46)
HEAT DEFLECTION TEMP.290°
BLACK COLOR, UL94V-0
- CONTACTS—0.35mm THICK PHOS-BRONZE PLATED
WITH HARD GOLD AND GOLD FLASH IN
SOLDER AREA.
- SHIELD—0.25mm THICK COPPER ALLOY,
PLATED WITH NICKEL.

CAVITY CONFIRMS TO FCC RULES AND REGULATIONS
PART 68,SUBPART F.

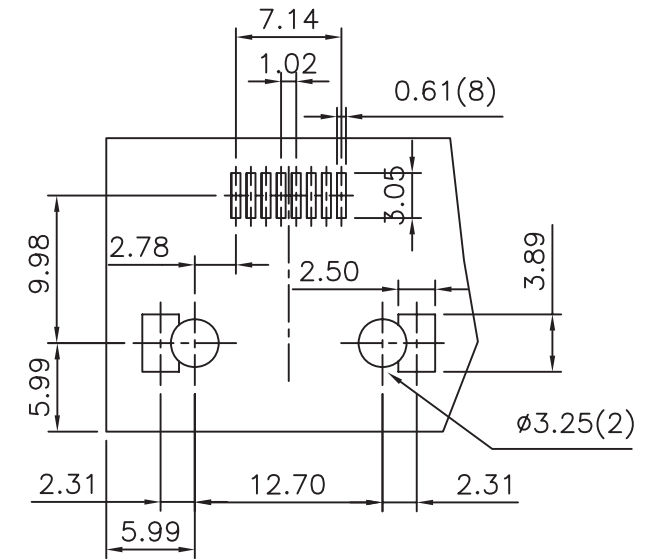

PCB LAYOUT
Ref.

RoHS Compliant

TOLERANCES ARE

MORETHANALL
PCB CONNECTORS
Cable ASSEMBLIES

煜倫股份有限公司

www.morethanall.com

DRAWING BY CY

CHECKED BY GENIUS

UNIT/mm

SCALE 1:1

DATE

SIZE A4

X.±
.X±
.XX±
.XXX±
ANG±

P PROJECTION

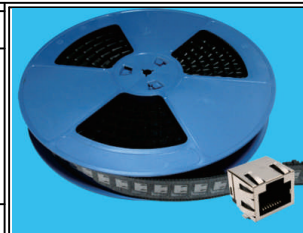

ORDER INFORMATION

MJWF13U-KF06EP1R-0808-LF

SERIES BLACK REEL 8P8C LEADFREE

EAR+POST/1
06u" GOLD
FULL SPRING

DESCRIPTION: MODULAR JACK, RJ45, WITHOUT LED'S
SHIELDED, SMT TYPE, SIDE ENTRY

MATERIALS:
 1.CARRIER-PS (0.50mm THICK TAPE).
 2.REEL-2mmTHICK PLASTIC WHEEL.
 3.COVER TAPE-PE (0.045mm-0.12mm THICK TAPE).

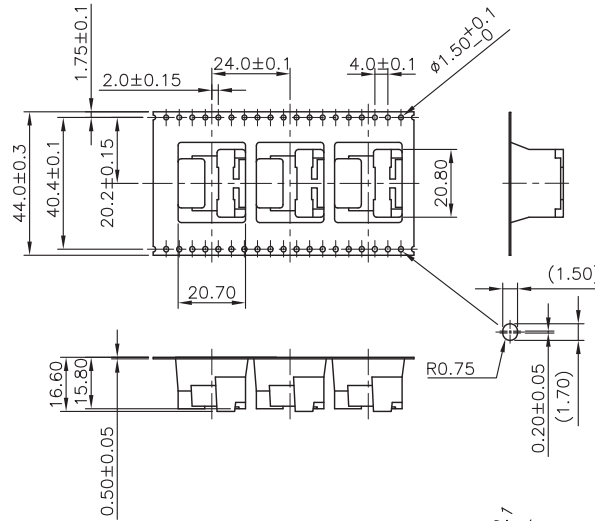

NOTES:
 1. 10 EMPTY CAVITIES FOR BOTH OF TOP AND BOTTOM OF THE CARRIER.
 2. 200 PCS PRODUCTS BE PACKAGED ON REEL.
 3. 軸外保護帶 361-319.

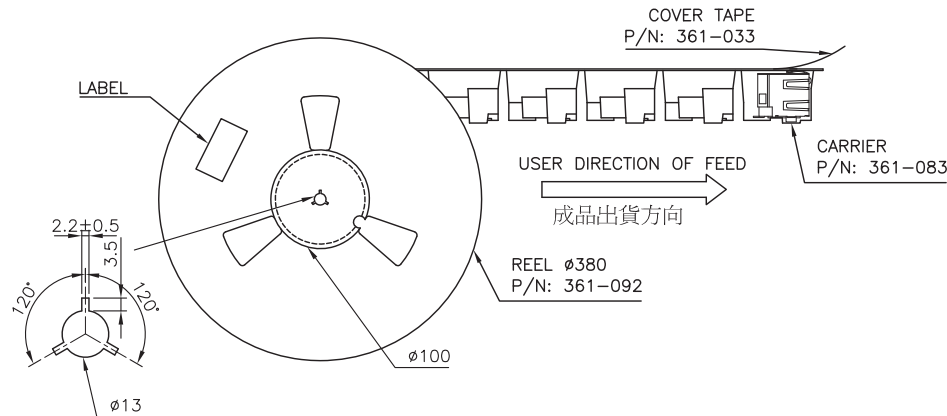
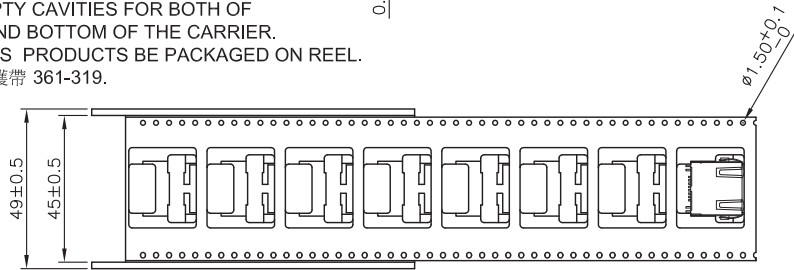

RoHS Compliance

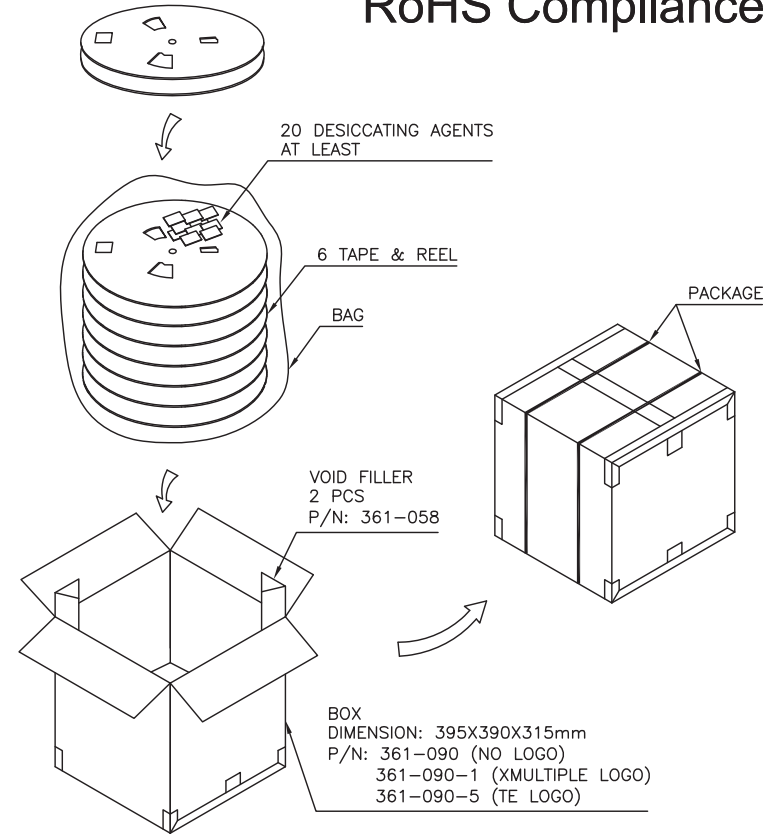

- KG	- KG	1200	6	200
GROSS WEIGHT (REF.)	NET WEIGHT (REF.)	PCS/BOX	REELS/BOX	PCS/REEL

RoHS Compliant

MORETHANALL
 PCB CONNECTORS
 Cable ASSEMBLIES

煜倫股份有限公司

www.morethanall.com

DRAWING BY CY

CHECKED BY GENIUS

UNIT/mm SCALE 1:1

DATE

SIZE A4

TOLERANCES ARE

X, ±
 X, ±
 .XX ±
 .XXX ±
 ANG ±

P PROJECTION

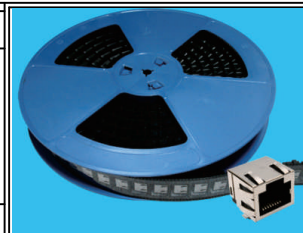

ORDER INFORMATION

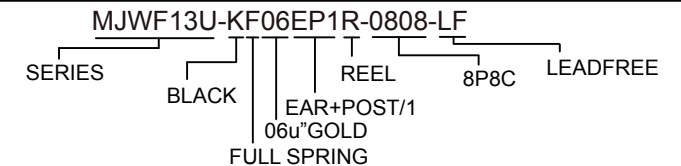

DESCRIPTION: TAPE & REEL PACKAGE SPEC.