

NOTE:

1. SOLDER TAIL TO BE WITHIN 0.05 UPWARD AND 0.2 DOWNWARD FROM Z-DATUM PLACE, AND COPLANALITY OF SOLDER TAILS TO BE WITHIN 0.12. MEASUREMENT POINT IS SOLDER TAILS TIP.

2. INSPECTION SYMBOL:

- : MANUFACTURER INSPECTION
- ◆ : Q.C INSPECTION

MPCI-W92-124-LF

LEADFREE

RoHS Compliant

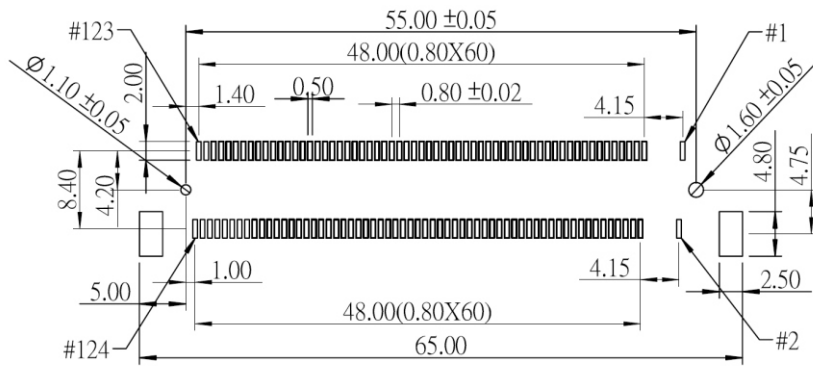

PCB LAYOUT

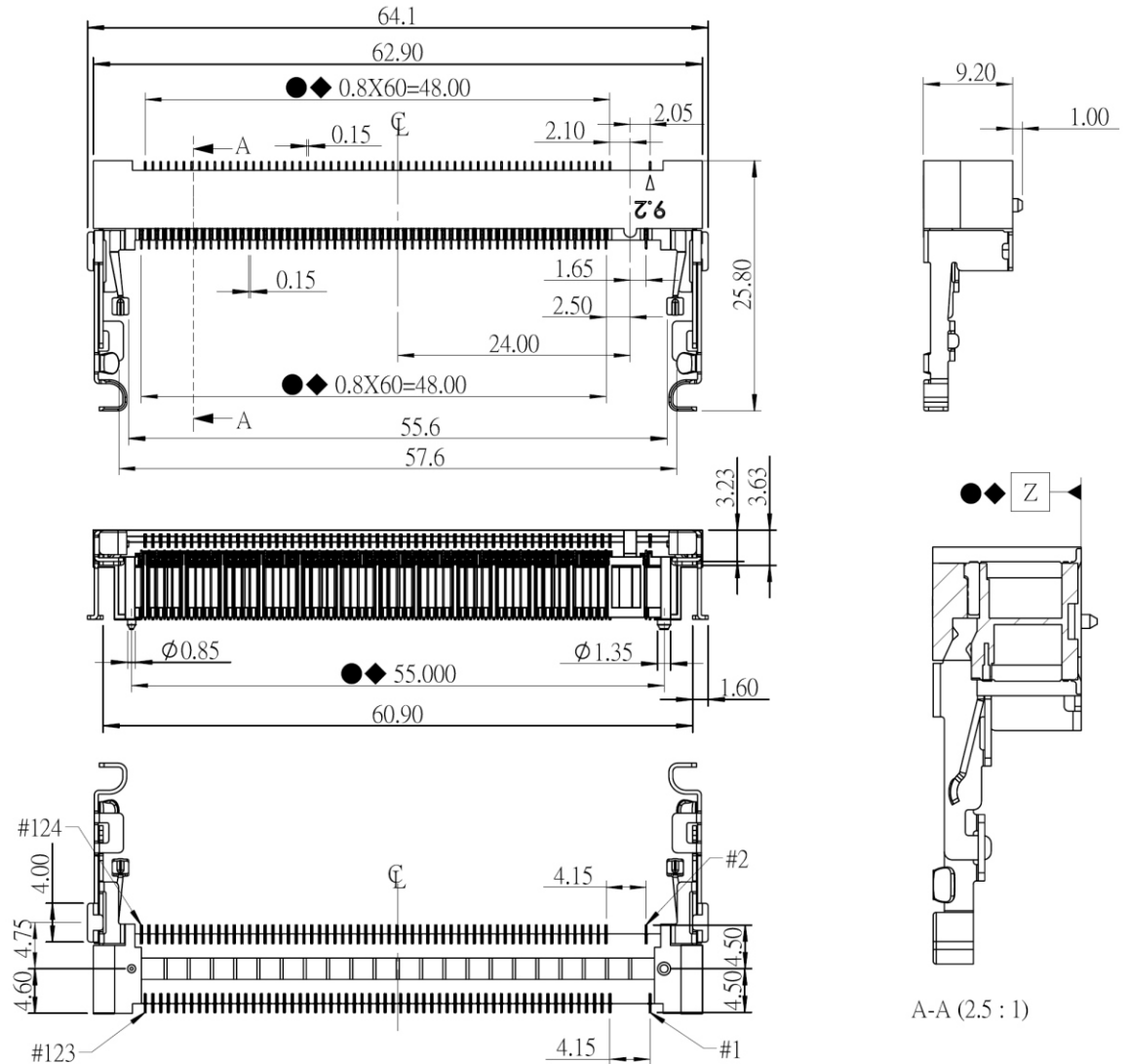

A-A (2.5 : 1)



PART NO. **MPCI-W92-124**

DWG NO. **MPCI-W92-124**

FILE NO.

UNIT / mm

SCALE 1:1

CHECKED BY CY

DRAWING BY

PROJECTION

TOLERANCES ARE

- .X ± 0.2
- .XX ±
- .XXX ±
- AWG

DESCRIPTION:

AREA

REVISIONS

HK

DATE

焜倫股份有限公司

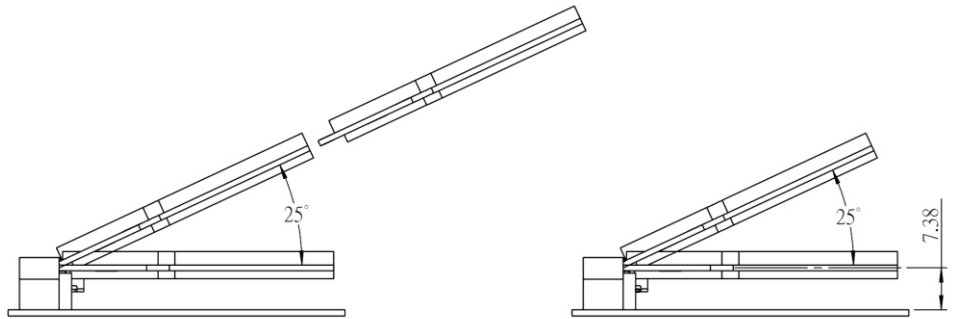
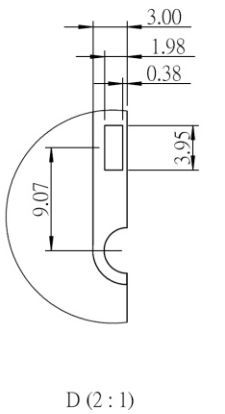
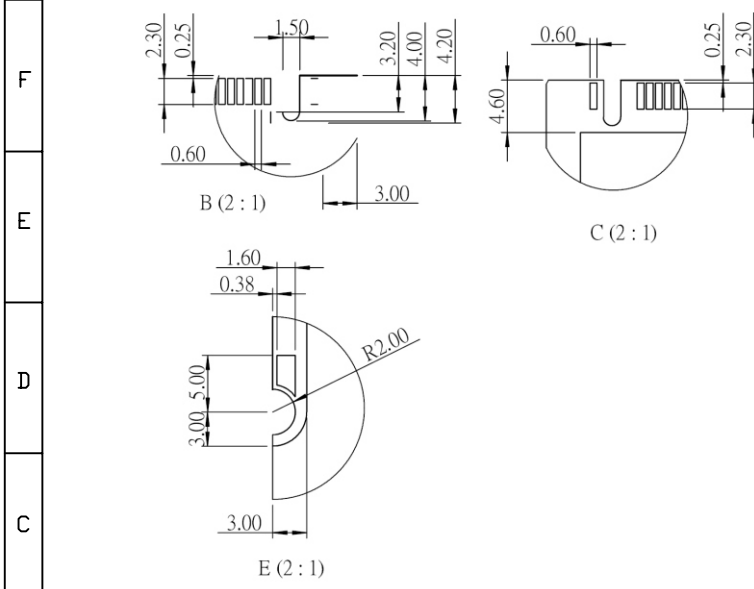
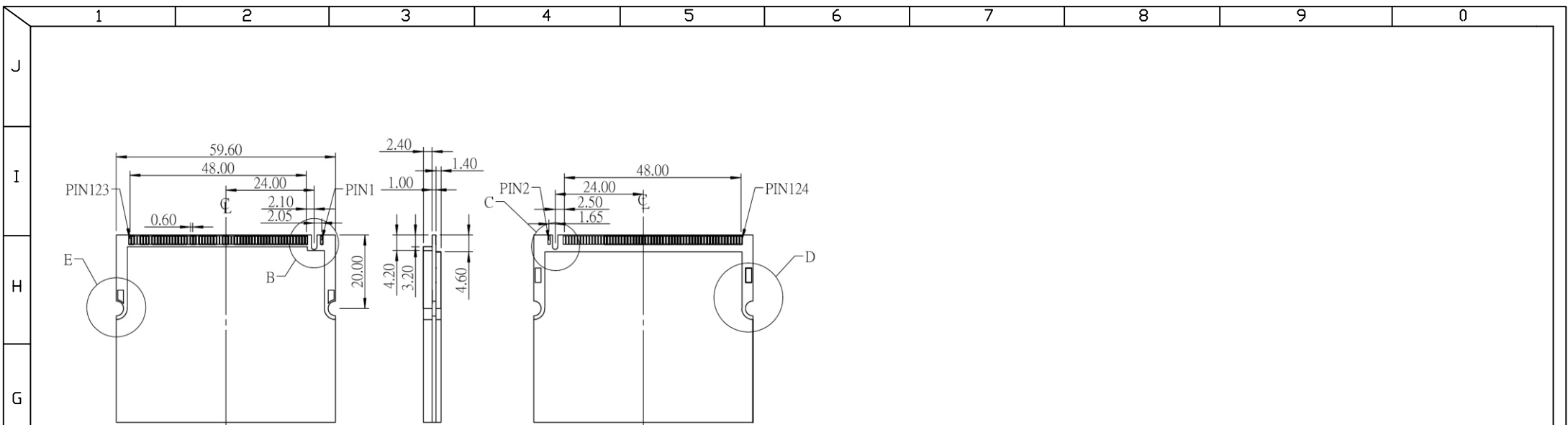

A			PART NO. MPCI-W92-124		TOLERANCES ARE .X ± 0.2 .XX ± .XXX ± AWG	DESCRIP TION:			
	焯倫股份有限公司		DWG NO. MPCI-W92-124						
B	UNIT / mm		SCALE 1 : 1		DRAWING BY	AREA	REVISIONS	HK	DATE
	PROJECTION 