

3P-16P

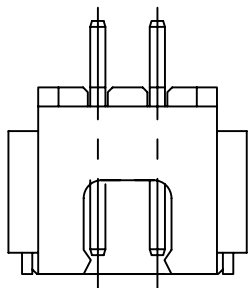
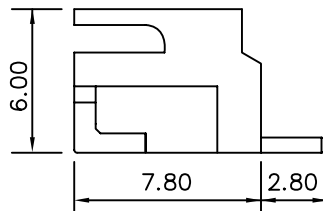
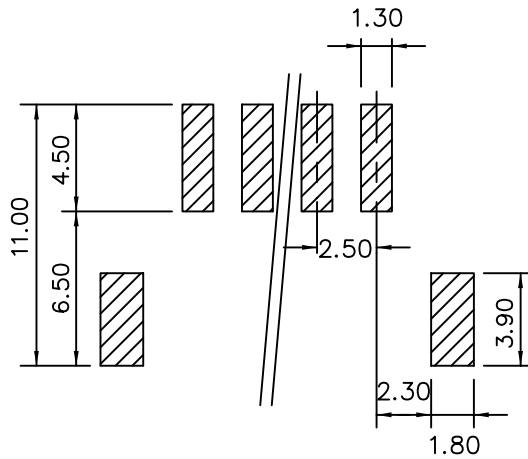
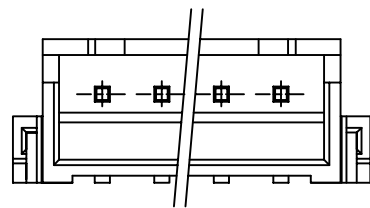

2P

Specifications

Current Rating: 3A AC, DC  
 Voltage Rating: 250V AC Maximum  
 Operating Temp: -25°C ~ +85°C  
 Contact Resistance: 10mΩ Max  
 Insulation Resistance: 1000MΩ Min  
 Withstanding Voltage: 1000V AC/minute  
 Pin: Brass/Gold Flash  
 Wafer: Nylon 6T, UL94V-0  
 Solder Tab: Brass/Tin Plated

Poles	Dimension mm		Part No.	Note.
	A	B		
2	2.5	10.0	XH-W-02	
3	5.0	12.5	XH-W-03	
4	7.5	15.0	XH-W-04	
5	10.0	17.5	XH-W-05	
6	12.5	20.0	XH-W-06	
7	15.0	22.5	XH-W-07	
8	17.5	25.0	XH-W-08	
9	20.0	27.5	XH-W-09	
10	22.5	30.0	XH-W-10	
11	25.0	32.5	XH-W-11	
12	27.5	35.0	XH-W-12	
13	30.0	37.5	XH-W-13	
14	32.5	40.0	XH-W-14	
15	35.0	42.5	XH-W-15	
16	37.5	45.0	XH-W-16	

XH-W-xx-LF  
 LEADFREE  
 RoHS Compliant

**MORETHANALL**  
 CONNECTORS  
 ASSEMBLIES

PART NO. XH-W-xx

DWG NO. XH-W-xx

FILE NO.

UNIT / mm

SCALE 1:1

CHECKED BY CY

DRAWING BY

PROJECTION

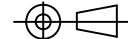

TOLERANCES ARE

.X ± 0.2  
 .XX ±  
 .XXX ±  
 AWG

DESCRIPTION:

XH2.5mm Wire-to-Board Header  
 SMT 90° Type

AREA

REVISIONS

HK

DATE

焜倫股份有限公司