

**FEATURES:**

- Half pitch 1.27mm(.050") series
- Centronic male connector I.D.C type for cable
- Assembly hood: Die- Cast and plastic(steel inner shell)
- Fully EMI/RFI shielded

**MATERIALS:**

- Housing And Cover: Plastic thermoplastic P.B.T UL94V-0 black
- Contacts: Phosphor bronze gold selective plated
- Shell: Steel nickel plated over copper

**ELECTRICAL:**

- Current Rating: 1 Amp
- Insulation Resistance: 500MΩ/Min
- Withstanding Voltage: 500V AC/Min
- Contact Resistance: 35mΩ Max
- Temperature Range: -55°C ~ +105°C

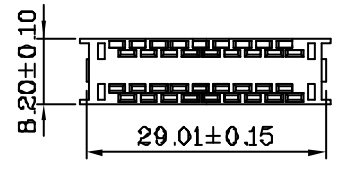
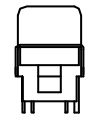
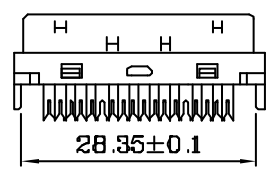

Termination Cover  
(1 Places)

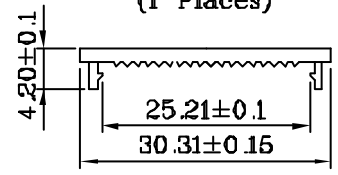

Wire Holder  
(2 Places)

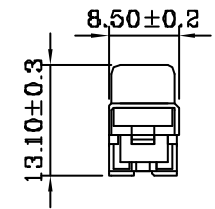
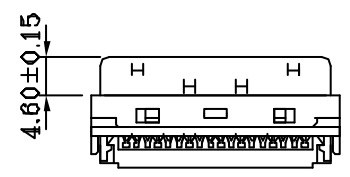
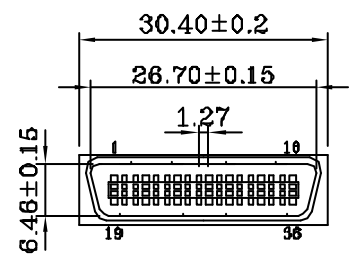
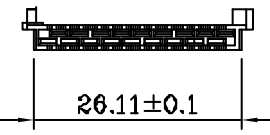
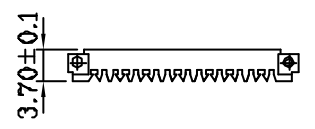

HPC-PFQ-036-LF  
LEADFREE

RoHS Compliant



PART NO. HPC-PFQ-036

DWG NO. HPC-PFQ-036

FILE NO.

UNIT / mm

SCALE 1:1

CHECKED BY CY

DRAWING BY

PROJECTION

TOLERANCES ARE

.X ± 0.2  
.XX ±  
.XXX ±  
AWG

DESCRIP TION:				
AREA	REVISIONS	HK	DATE	

煜倫股份有限公司

**FEATURES:**

- Plastic hood with spring latches
- Steel inner shell
- Full EMI/RFI shielded

**MATERIALS:**

- Hood: Plastic ABS
- Inner Shell: Steel , Nickel plated
- Latch: Stainless steel

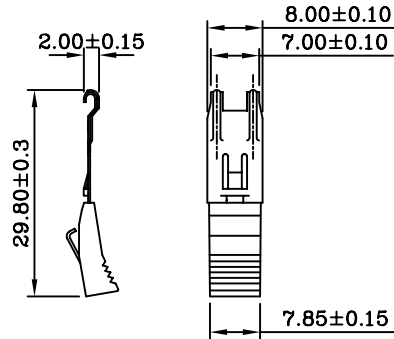
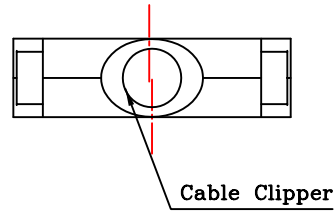
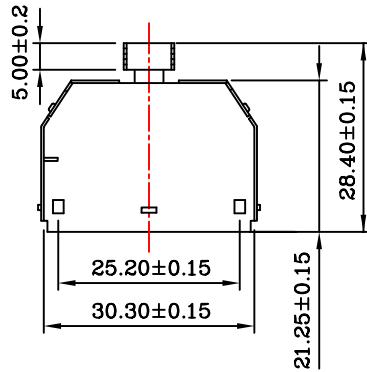
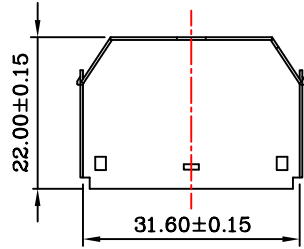

LS: Fish Hooks

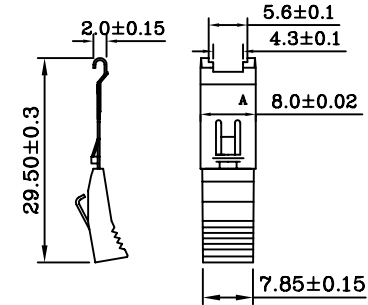

LS1: Fish Hooks

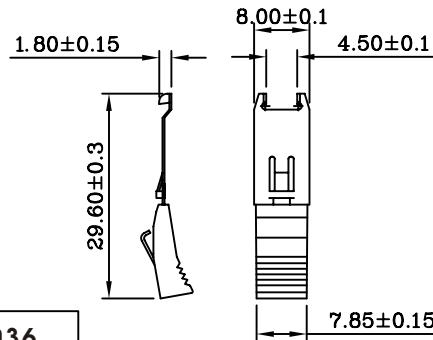
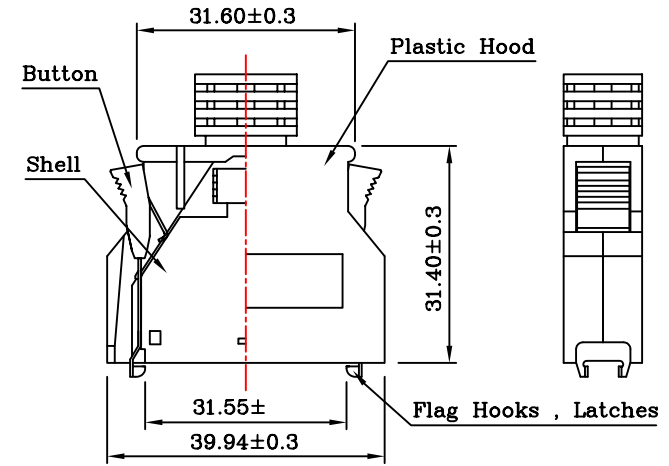
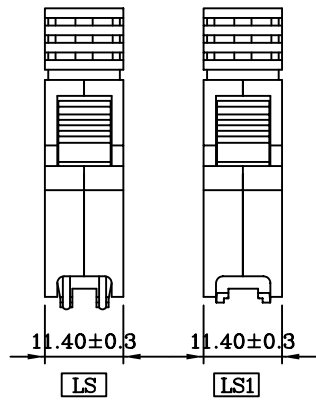
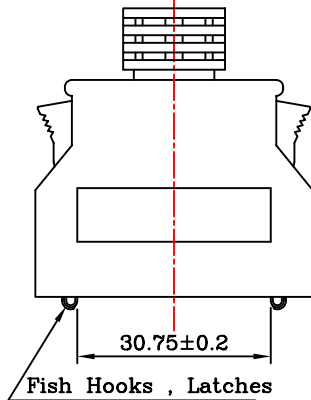

**MORETHANALL**  
CONNECTORS  
ASSEMBLIES

PART NO. **HPC-PFQ-036**

DWG NO. **HPC-PFQ-036**

FILE NO.

UNIT / mm

SCALE 1:1

CHECKED BY **SS Flag Hooks**

DRAWING BY

PROJECTION

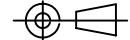

TOLERANCES ARE

.X ± 0.2  
.XX ±  
.XXX ±  
AWG

DESCRIPTION:

1.27mm(.050") Series 36P

AREA

REVISIONS

HK

DATE

焯倫股份有限公司