

Note:

1. Material:

- 1.1 Insulator: LCP/PBT UL 94-V0 rated.
- 1.2 Contact: Brass, t=0.25mm.
- 1.3 Shell: Brass或 K7, t=0.30mm.

2. Specification:

- 2.1 Rated voltage and current: 1.5A at 250V AC minimum.
- 2.2 Dielectric withstanding voltage: 500V AC/1 minute without breakdown.
- 2.3 Contact resistance: Before life test 30m ohm max,  
After life test 50m ohm max.
- 2.4 Insulation resistance: 1000M ohm min.
- 2.5 Insertion force: 35 Newtons maximum.
- 2.6 Extraction force: 10 Newtons minimum.
- 2.7 Solderability: Terminal shall be immersed in flux before test, Then dip in molten solder for 5±0.5 sec. At 245±5°C.

3. Finishes:

- 3.1 Contacts: Gold flashed 1u", 3u", 5u", 10U", 15u", 30u".
- 3.2 Shell: Nickel plated.

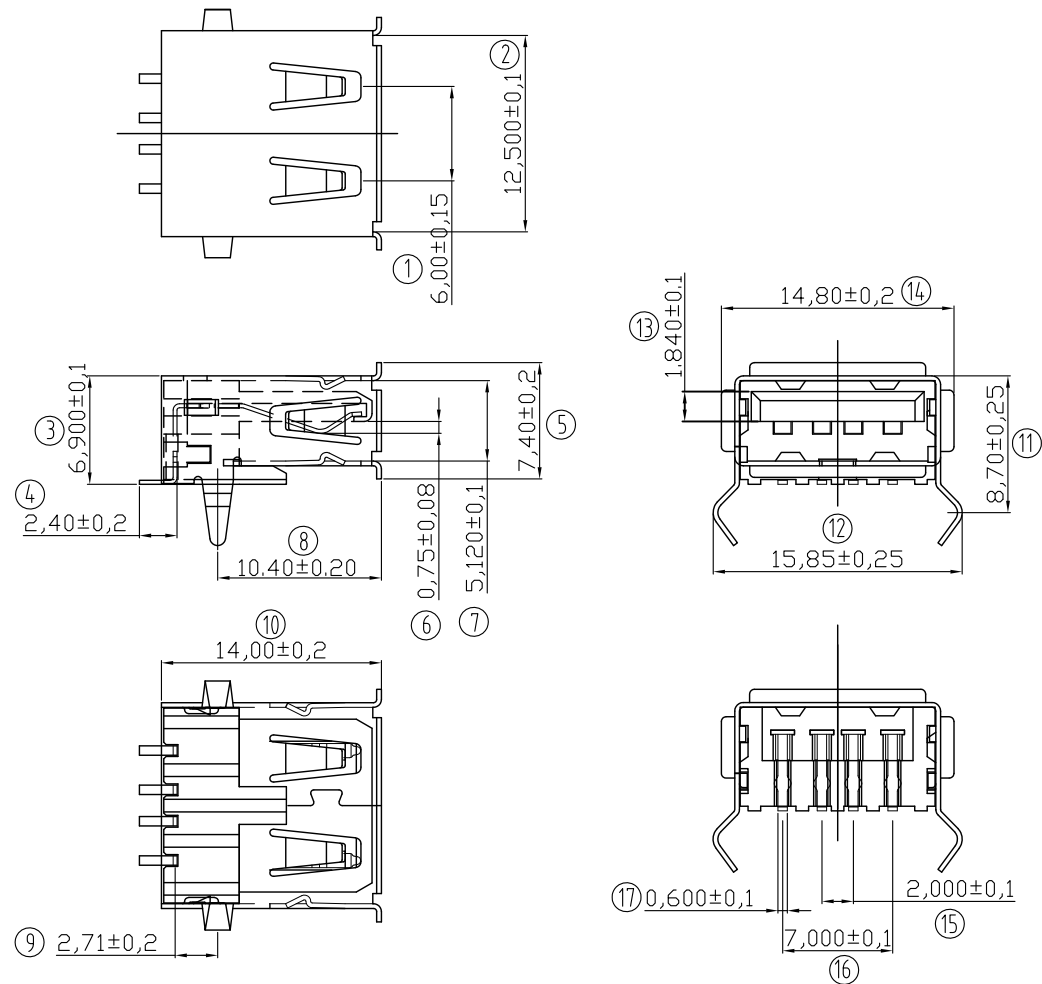
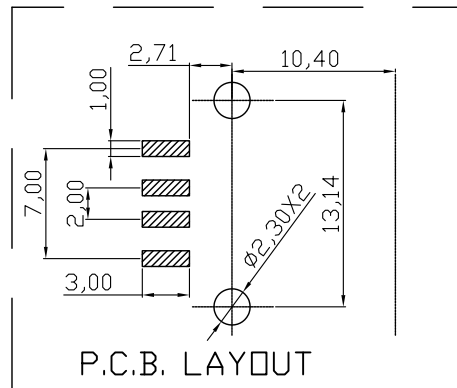

3	SHELL	1	K7\ BRASS	T=0.30±0.02mm	Nickel Plated	D2950XX-C
2	CONTACT	5	BRASS	T=0.25±0.02mm	Gold flashed	A4120XX
1	HOUSING	1	LCP/P.B.T		Black/White	JCH0046
No.	Part Name	Q'ty	Material	Thickness	Finish	Notes

RoHS Compliant

TOLERANCES ARE

**MORETHANALL**  
PCB CONNECTORS  
Cable ASSEMBLIES

煜倫股份有限公司

www.morethanall.com

DRAWING BY CY

CHECKED BY GENIUS

UNIT / mm SCALE 1 : 1

DATE

SIZE A4

X, ±  
.X ±  
.XX ±  
.XXX ±  
ANG ±

P PROJECTION

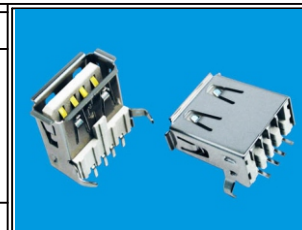

ORDER INFORMATION

USB-SWXCxx-4A-LF  
SERIES | LEADFREE  
FEMALE | 4 PIN A TYPE  
BK:BLACK  
WH:WHITE  
NON BACK CAP  
90°SMT

DESCRIPTION: USB A FEMALE SMT