

NOTES:

1. WATERPROOF RATE: IP67
IP67: IMMERSED IN 1M WATER FOR 30 MINUTES
2. ELECTRICAL CHARACTERISTICS:
 - 1-1. RATING: 30V 1A
 - 1-2. CONTACT RESISTANCE: 30mΩ MAX.(INITIAL)
 - 1-3. DIELECTRIC WITHSTANDING VOLTAGE: 500V AC FOR ONE MINUTE
 - 1-4. INSULATION RESISTANCE: 100MΩ MIN. MEASURED BY 500 VDC
3. OTHER GENERAL SPEC. TO REFER "2UP2002 SERIES SPEC".
4. TO CONFORM TO SINGATRON HAZARDOUS SUBSTANCE FREE SPEC.
5. GREEN PRODUCT IDENTIFICATION LABEL ON PACKAGING

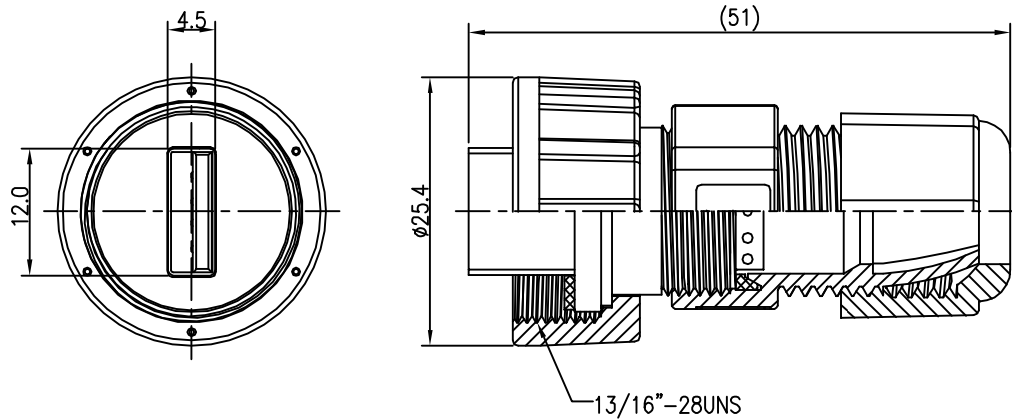

NO	DESCRIPTION	QTY	MATERIAL	PLATING & COLOR
J	SEALING NUT	1	NYLON66	BLACK
I	SEAL	1	EPDM	BLACK
H	CLAMP RING	1	NYLON66	BLACK
G	GASKET	1	SILICONE	BLACK
F	SCREW NUT	1	NYLON+33%GF	BLACK
E	PCB	1	FR-4	GREEN
D	BODY	1	NYLON+33%GF	BLACK
C	LIGUID GLUE	1		BLACK
B	USB A PLUG	1	P/N:2UP2002-4P0111	N/A
A	GASKET	1	EPDM	BLACK

WUB-PA-4A-LF
LEADFREE
RoHS Compliant

MORETHANALL
CONNECTORS
ASSEMBLIES

PART NO. WUB-PA-4A

DWG NO. WUB-PA-4A

FILE NO.

UNIT / mm

SCALE 1:1

CHECKED BY CY

DRAWING BY

PROJECTION

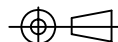

TOLERANCES ARE

.X ± 0.2
.XX ±
.XXX ±
AWG

DESCRIPTION: WATERPROOF USB2.0 A PLUG

AREA

REVISIONS

HK

DATE

煜倫股份有限公司