

Notes: (Unless Otherwise Specified)

1. Recommend Panel Thickness: 0.8 to 4.0 mm.
2. Recommend Torque: 6.0~7.0 Kgf-cm.
3. RoHS Compliant.

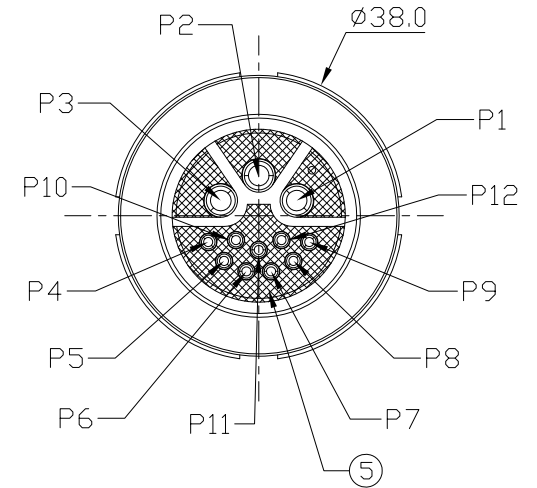

6	O-Ring	Silicone Color: Red	1
5	Glue	Epoxy Color: Black	
4	Gasket	Silicone Color: Black	1
3	Spanner Nut	Thermoplastic Color: Black	1
2	Contacts	Copper Alloy Finish: Gold Flash	12
1	Housing	Thermoplastic Color: Black	1
Item	Part Name	Material / Finish	Qty

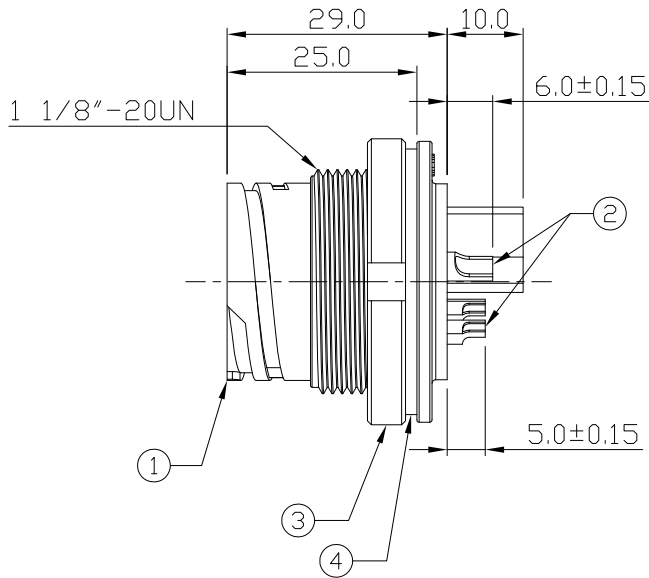
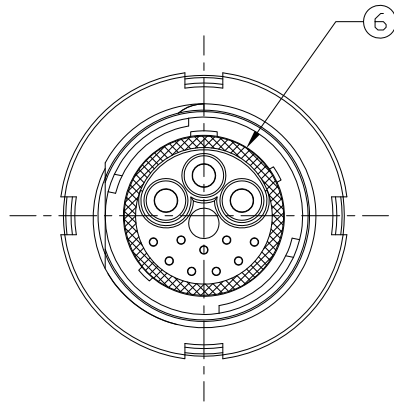
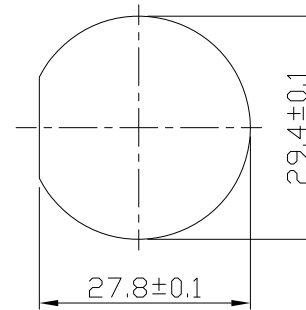

Recommend
Panel Cut-Out

W29-PSPB-3+9-LF
LEADFREE
RoHS Compliant

MORETHANALL
CONNECTORS
ASSEMBLIES

PART NO. W29-PSPB-3+9

DWG NO. W29-PSPB-3+9

FILE NO.

CHECKED BY CY

DRAWING BY

TOLERANCES ARE

X ±
.X ± 0.5
.XX ± 0.2
.XXX ± 0.05
ANG ± 1°

DESCRIPTION: Hybrid C5 20A+5A 3P+9P Panel Male Solder Twist Lock

焯倫股份有限公司

UNIT / mm

SCALE 1:1

PROJECTION

AREA

REVISIONS

DATE