

① 外壳下盖

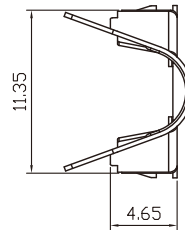

② 外壳上盖

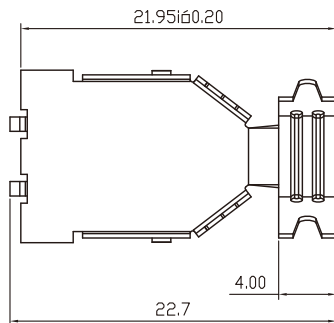
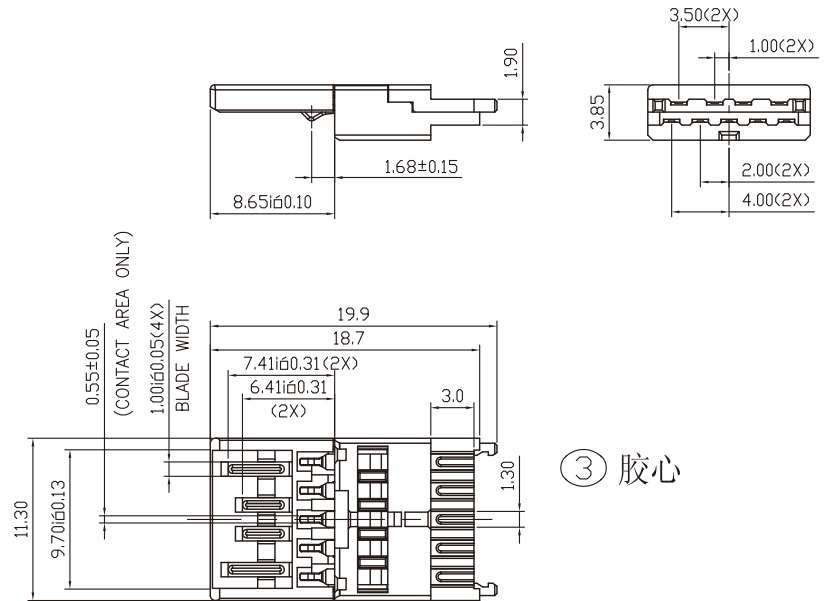
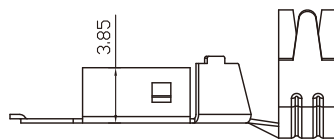

③ 胶心

1. ELECTRICAL CHARACTERISTICS:
 VOLTAGE RATING:30V DC/AC;CURRENT RATING:1A MAX;.
 CONTACT RESISTANCE:30mΩ MAX;
 INSULATION RESISTANCE:100MΩ MIN AT 500V DC.
 DIELECTRIC STRENGTH:750V AC/1MINUTE;
2. MECHANICAL CHARACTERISTICS:
 INSERTION FORCE:3.5Kgf MAX;WITHDRAWAL:1.0~3.5Kgf.
 DURABILITY CYCLE:5000 CYCLES, AND 200 CYCLES PER HOUR.

1	USB3.0-A公头-下盖	1	SPCC T=0.30mm镀金或镀镍	
2	USB3.0-A公头-上盖	1	SPCC T=0.30mm镀镍	
3	USB3.0-A公胶心	4P端子座	1	PBT, UL94 V-0 (蓝色 300C)
		5P端子座	1	PBT, UL94 V-0 (蓝色 300C)
		5P端子	5	C5191, T=0.20mm, 前金后锡
		4P端子	4	C2680, T=0.20mm, 前金后锡
项次	品名	数量	规格	备注

RoHS Compliant

TOLERANCES ARE

MORETHANALL
 PCB CONNECTORS
 Cable ASSEMBLIES

煜倫股份有限公司

www.morethanall.com

DRAWING BY CY

CHECKED BY GENIUS

UNIT/ mm

SCALE 1:1

DATE

SIZE A4

PJECTION

X, ±
 .X ± 0.20
 .XX ± 0.10
 .XXX ± 0.05
 ANG ± 5°



ORDER INFORMATION

USB-PSBL-9A-LF
 SERIES | LEADFREE
 | 9 PIN A TYPE
 | BLUE
 | SOLDER
 MALE

DESCRIPTION: USB3.0 A公焊线式(三件套)