

NOTE:

1. ALL DIMENSIONS ARE IN MILLIMETERS, BRACKETED DIMENSIONS ARE IN INCHES.
2. GENERAL TOLERANCES MAX.±0.20mm.
3. MATERIAL & □ : SEE PAGE 3 OF 3.

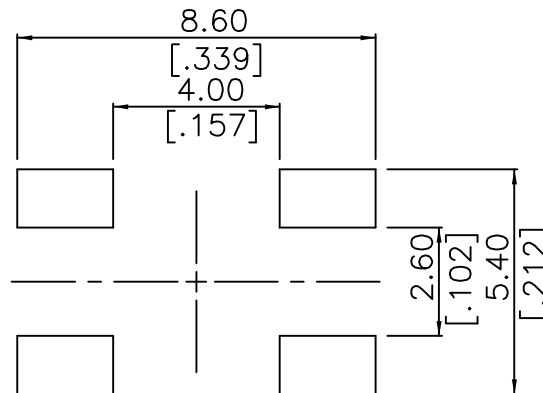
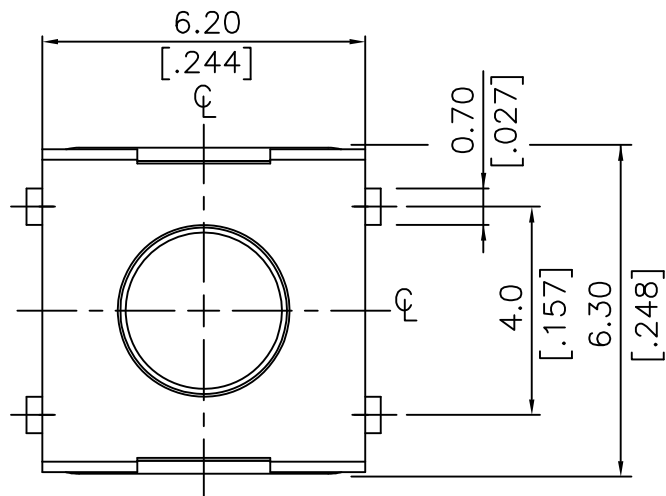

TSW66-V38JR-xxx-LF
LEADFREE

FORCE
180:180g
260:260g
360:360g

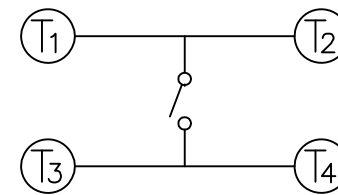

P.C.B. LAYOUT SCALE 8:1

CIRCUIT DIAGRAM

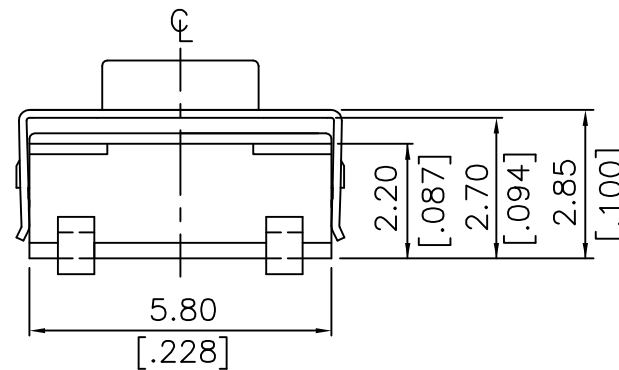
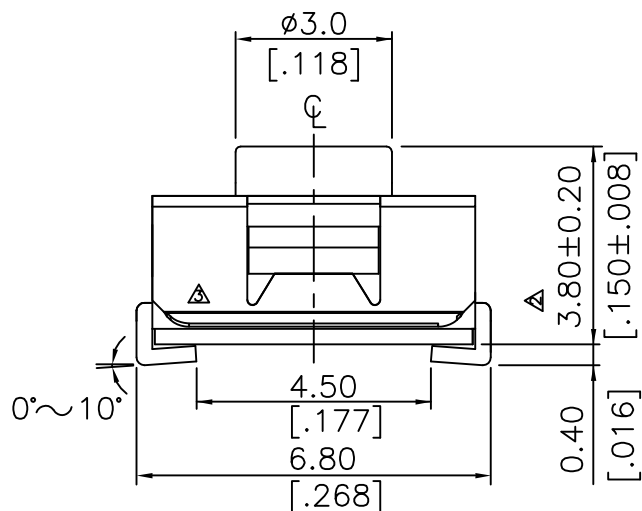

RoHS Compliant

MORETHANALL
CONNECTORS
ASSEMBLIES

PART NO. TSW66-V38JR-xxx

DWG NO. TSW66-V38JR-xxx

CHECKED BY CY

TOLERANCES ARE

DESCRIPTION:

**TACT SWITCH 6X6 WASHABLE
J TYPE (H=3.80mm)**

FILE NO.

DRAWING BY

.X±0.2
.XX±
.XXX±
AWG

AREA

REVISIONS

HK

DATE

煜倫股份有限公司

UNIT / mm

SCALE 1:1

PROJECTION

1 2 3 4 5 6 7 8 9 0

J
I
H
G
F
E
D
C
B
A

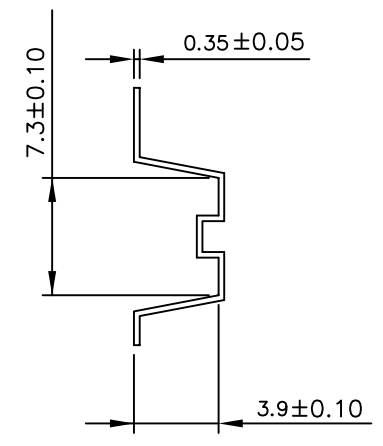
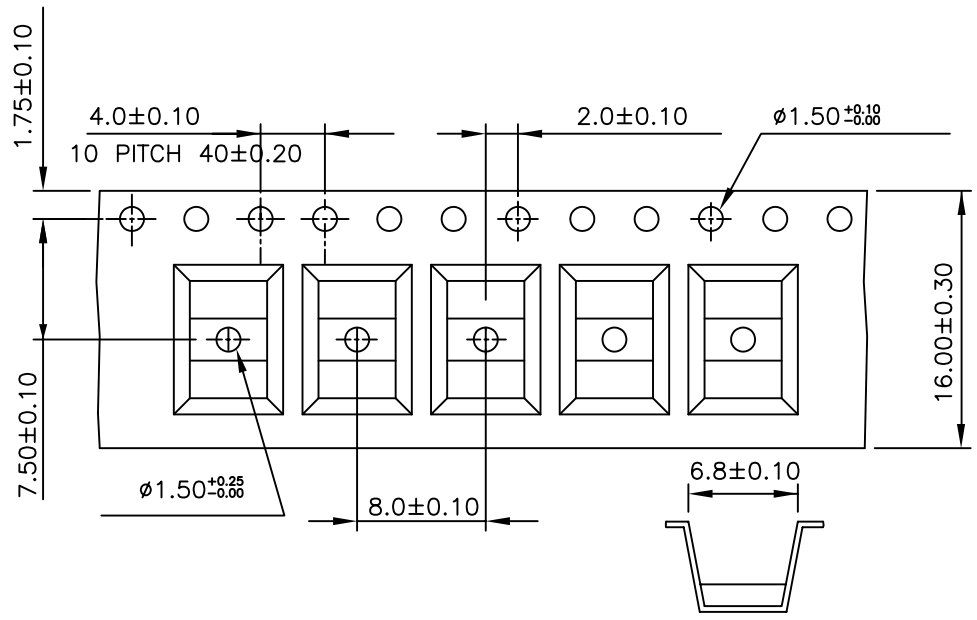

CARRIER TYPE

COVER TYPE

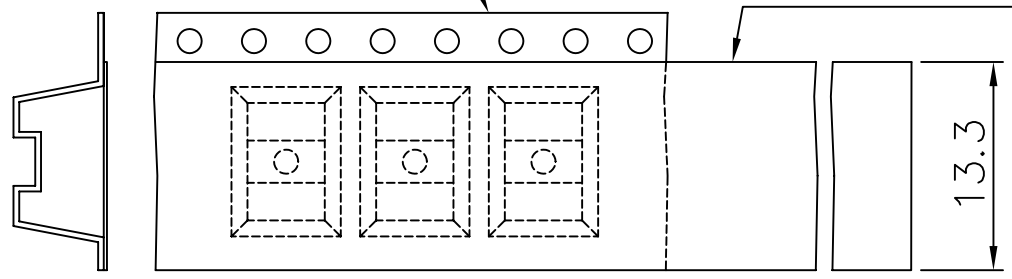

MORETHANALL
CONNECTORS
ASSEMBLIES

PART NO. TSW66-V38JR-xxx

DWG NO. TSW66-V38JR-xxx

CHECKED BY CY

TOLERANCES ARE

DESCRIP TION:

FILE NO.

DRAWING BY

.X ±
.XX ±
.XXX ±
AWG

AREA	REVISIONS	HK	DATE
------	-----------	----	------

焯倫股份有限公司

UNIT / mm

SCALE 1:1

PROJECTION